



Revision Notes
Class 12 Physics
Chapter 7– Alternating Current

ALTERNATING CURRENT

1. THE ALTERNATING CURRENT

The magnitude of alternating current changes continuously with time and its direction is reversed periodically. It is represented by

$$I = I_0 \sin \omega t \text{ OR } I = I_0 \cos \omega t$$

$$\omega = \frac{2\pi}{T} = 2\pi\nu$$

2. AVERAGE VALUE OF ALTERNATING CURRENT

The mean or average value of alternating current over any half cycle is defined as that value of steady current which would send the same amount of charge through a circuit in the time of half cycle (i.e. $T/2$) as is sent by the alternating current through the same circuit, in the same time.

To calculate the mean or average value, let an alternating current be represented by $I = I_0 \sin \omega t$... (1)

If the strength of current is assumed to remain constant for a small time, dt , then small amount of charge sent in a small time dt is

$$dq = Idt \quad \dots(2)$$

Let q be the total charge sent by alternating current in the first half cycle (i.e. $0 \rightarrow T/2$).

$$q = \int_0^{T/2} Idt$$



$$\begin{aligned} \text{Using (1), we get, } q &= \int_0^{T/2} I_0 \sin \omega t \cdot dt = I_0 \left[-\frac{\cos \omega t}{\omega} \right]_0^{T/2} \\ &= -\frac{I_0}{\omega} \left[\cos \omega \frac{T}{2} - \cos 0^\circ \right] \\ &= -\frac{I_0}{\omega} [\cos \pi - \cos 0^\circ] \quad (\because \omega T = 2\pi) \\ q &= -\frac{I_0}{\omega} [-1 - 1] = \frac{2I_0}{\omega} \quad \dots(3) \end{aligned}$$

If I_m represents the mean or average value of alternating current over the 1st half cycle, then

$$q = I_m \times \frac{T}{2} \quad \dots(4)$$

$$\text{From (3) and (4), we get } I_m \times \frac{T}{2} = 2 \frac{I_0}{\omega} = \frac{2I_0 \cdot T}{2\pi} \quad \dots(5)$$

$$\text{or } I_m = \frac{2}{\pi} I_0 = 0.637 I_0$$

Hence, mean or average value of alternating current over positive half cycle is 0.637 times the peak value of alternating current, i.e., 63.7% of the peak value.

3. A.C. CIRCUIT CONTAINING RESISTANCE ONLY

Let a source of alternating e.m.f. be connected to a pure resistance R , Figure. Suppose the alternating e.m.f. supplied is represented by

$$E = E_0 \sin \omega t \quad \dots(1)$$

Let I be the current in the circuit at any instant t . The potential difference developed across R will be IR . This must be equal to e.m.f. applied at that instant, i.e., $IR = E = E_0 \sin \omega t$

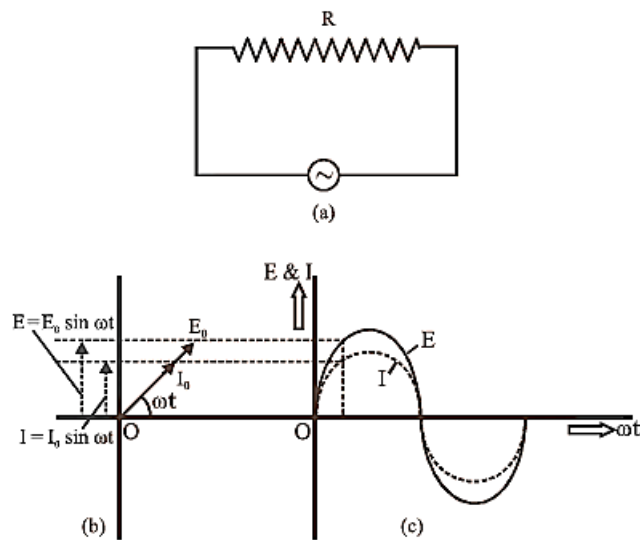

$$\text{or } I = \frac{E_0}{R} \sin \omega t = I_0 \sin \omega t \quad \dots(2)$$

where $I_0 = E_0 / R$, maximum value of current.

This is the form of alternating current developed.

Comparing $I_0 = E_0 / R$ with Ohm's law equation, viz. current = voltage/resistance, we find that resistance to a.c. is represented by R-which is the value of resistance to d.c. Hence behaviour of R in d.c. and a.c. circuit is the same, R can reduce a.c. as well as d.c. equally effectively.

Comparing (2) and (1), we find that E and I are in phase. Therefore, in an a.c. circuit containing R only, the voltage and current are in the same phase, as shown in figure.

3.1 Phasor Diagram

In the a.c. circuit containing R only, current and voltage are in the same phase. Therefore, in figure, both phasors \vec{I}_0 and \vec{E}_0 are in the same direction making an angle (ωt) with OX . This is so for all times. It means that the phase angle between alternating voltage and alternating current through R is zero.



$$I = I_0 \sin \omega t \text{ and } E = E_0 \sin \omega t$$

4. A.C. CIRCUIT CONTAINING INDUCTANCE ONLY

In an a.c. circuit containing L only alternating current I lags behind alternating voltage E by a phase angle of 90° , i.e., by one fourth of a period. Conversely, voltage across L leads the current by a phase angle of 90° . This is shown in figure.

Figure (b) represents the vector diagram or the phasor diagram of a.c. circuit containing L only. The vector representing \vec{E}_0 makes an angle (ωt) with OX . As current lags behind the e.m.f. by 90° , therefore, phasor representing \vec{I}_0 is turned clockwise through 90° from the direction of

$$\vec{E}_0 \cdot I = I_0 \sin \left(t - \frac{\pi}{2} \right), I_0 = \frac{V_0}{X_L}, X_L = \omega L$$

A pure inductance offers zero resistance to dc. It means a pure inductor cannot reduce dc. The units of inductive reactance

$$X_L = \omega L \Rightarrow \frac{1}{\text{sec}} (\text{henry}) = \frac{1}{\text{sec}} \frac{1}{\text{amp} / \text{sec}} = \text{ohm}$$

The dimensions of inductive reactance are the same as those of resistance.

5. A.C. CIRCUIT CONTAINING CAPACITANCE ONLY

Let a source of alternating e.m.f. be connected to a capacitor only of capacitance C , figure. Suppose the alternating e.m.f. supplied is

$$E = E_0 \sin \omega t \quad \dots(1)$$

The current flowing in the circuit transfers charge to the plates of the capacitor. This produces a potential difference between the plates. The capacitor is alternately charged and discharged as the current reverses each half cycle. At any instant t , suppose q is the charge on the capacitor. Therefore, potential difference across the plates of capacitor $V = q/C$.



At every instant, the potential difference V must be equal to the e.m.f. applied i.e.,

$$V = \frac{q}{C} = E = E_0 \sin \omega t$$

$$\text{Or } q = C\varepsilon_0 \sin \omega t$$

If I is instantaneous value of current in the circuit at instant t , then

$$I = \frac{dq}{dt} = \frac{d}{dt}(C\varepsilon_0 \sin \omega t)$$

$$I = CE_0(\cos \omega t)\omega$$

$$I = \frac{E_0}{1/\omega C} \sin(\omega t + \pi/2) \quad \dots(2)$$

The current will be maximum i.e.,

$$I = I_0, \text{ when } \sin(\omega t + \pi/2) = \text{maximum} = 1$$

$$\therefore \text{ From (2), } I_0 = \frac{E_0}{1/\omega C} \times 1 \quad \dots(3)$$

$$\text{Put in (2), } I = I_0 \sin(\omega t + \pi/2) \quad \dots(4)$$

This is the form of alternating current developed.

Comparing (4) with (1), we find that in an a.c. circuit containing C only, alternating current leads the alternating e.m.f. by a phase angle of 90° . This is shown in figure (b) and (c).

The phasor diagram or vector diagram of a.c. circuit containing C only is shown in figure (b). The phasor \vec{I}_0 is turned anticlockwise through 90° from the direction of phasor \vec{E}_0 . Their projections on YOY' give the instantaneous values E and I as shown in figure (b). When E_0 and I_0 rotate with frequency ω , curves in figure (c) are generated.

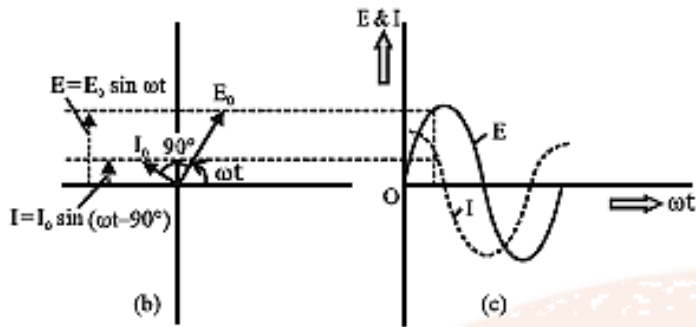
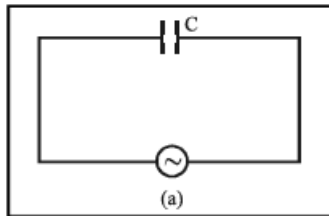

Comparing (3) with Ohm's law equation, viz current = voltage/resistance, we find that $(1/\omega C)$ represents effective resistance offered by the capacitor. This is called capacitive reactance and is denoted by X_c ,

$$\text{Thus, } X_c = \frac{1}{\omega C} = \frac{1}{2\pi VC}$$

The capacitive reactance limits the amplitude of current in a purely capacitive circuit in the same way as the resistance limits the current in a purely resistive circuit. Clearly, capacitive reactance varies inversely as the frequency of a.c. and also inversely as the capacitance of the condenser.

In a d.c. circuit, $v = 0, \therefore XC = \infty$

$$X_c = \frac{1}{\omega C} = \text{sec} \frac{1}{\text{farad}} = \frac{\text{sec}}{\text{coulomb/ volt}}$$

$$X_c = \frac{\text{voltsec.}}{\text{amp.sec}} = \text{ohm}$$

5. A.C. CIRCUIT CONTAINING RESISTANCE, INDUCTANCE AND CAPACITANCE AND SERIES

6.1 Phasor Treatment

Let a pure resistance R , a pure inductance L and an ideal capacitor of capacitance C be connected in series to a source of alternating e.m.f. figure. As R, L, C are in series, therefore, current at any instant through the three elements has the same amplitude and phase. Let it be represented by $I = I_0 \sin \omega t$

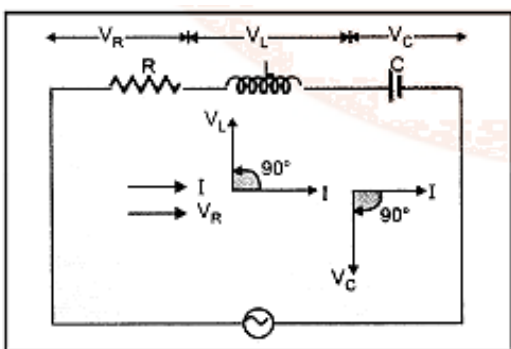

However, voltage across each element bears a different phase relationship with the current. Now,

(i) The maximum voltage across R is

$$\bar{V}_R = \bar{I}_0 R$$

In figure, current phasor \vec{I}_0 is represented along OX .

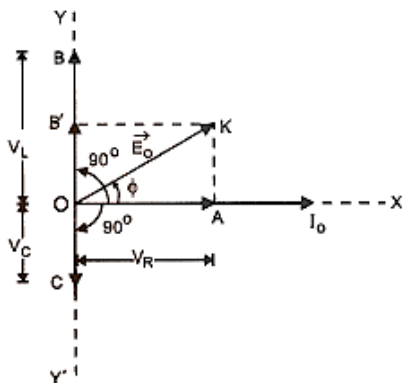



As \vec{V}_R is in phase with current, it is represented by the vector \overline{OA} , along OX.

(ii) The maximum voltage across L is $\vec{V}_L = \vec{I}_0 X_L$

As voltage across the inductor leads the current by 90° , it is represented by OB along OY, 90° ahead of \vec{I}_0 .

(iii) The maximum voltage across C is $\vec{V}_C = \vec{I}_0 X_C$

As voltage across the capacitor lags behind the alternating current by 90° , it is represented by \overline{OC} rotated clockwise through 90° from the direction of \vec{I}_0 . \overline{OC} is along OY'

6.2 Analytical Treatment of RLC series circuit

Let a pure resistance R, a pure inductance L and an ideal condenser of capacity C be connected in series to a source of alternating e.m.f. Suppose the alternating e.m.f. supplied is

$$E = E_0 \sin \omega t \quad \dots(1)$$

At any instant of time t, suppose

q = charge on capacitor

I = current in the circuit

$\frac{dI}{dt}$ = rate of change of current in the circuit

potential difference across the condenser = $\frac{q}{C}$

potential difference across inductor = $L \frac{dI}{dt}$

potential difference across resistance = RI

∴ The voltage equation of the circuit is

$$L \frac{dI}{dt} + RI + \frac{q}{C} = E = E_0 \sin \omega t \quad \dots(2)$$

As $I = \frac{dq}{dt}$, therefore, $\frac{dI}{dt} = \frac{d^2q}{dt^2}$

∴ The voltage equation becomes

$$L \frac{d^2q}{dt^2} + R \frac{dq}{dt} + \frac{q}{C} = E_0 \sin \omega t \quad \dots(3)$$

This is like the equation of a forced, damped oscillator. Let the solution of equation (3) be

$$q = q_0 \sin(\omega t + \theta)$$

$$\therefore \frac{dq}{dt} = q_0 \omega \cos(\omega t + \theta)$$

$$\frac{d^2q}{dt^2} = -q_0 \omega^2 \sin(\omega t + \theta)$$

Substituting these values in equation (3), we get

$$L[-q_0 \omega^2 \sin(\omega t + \theta)] + Rq_0 \omega \cos(\omega t + \theta)$$

$$\frac{q_0}{C} \sin(\omega t + \theta) = E_0 \sin \omega t \quad q_0 \omega \left[R \cos(\omega t + \theta) - \omega L \sin(\omega t + \theta) + \frac{1}{\omega C} \sin(\omega t + \theta) \right] = E_0 \sin \omega t$$

As $\omega_L = X_L$ and $\frac{1}{\omega C} = X_C$, therefore $q_0 \omega [R \cos(\omega t + \theta) + (X_C - X_L) \sin(\omega t + \theta)] = E_0 \sin \omega t$

Multiplying and dividing by,

$$Z = \sqrt{R^2 + (X_C - X_L)^2}, \text{ we get}$$

$$q_0 \omega Z \left[\frac{R}{Z} \cos(\omega t + \theta) + \frac{X_C - X_L}{Z} \sin(\omega t + \theta) \right] = E_0 \sin \omega t \quad \dots(4)$$

$$\frac{R}{Z} = \cos \phi \text{ and } \frac{X_C - X_L}{Z} = \sin \phi \quad \dots(5)$$

$$\phi = \frac{X_C - X_L}{Z} \quad \dots(6)$$

$$\therefore q_0 \omega Z [\cos(\omega t + \theta) \cos \phi + \sin(\omega t + \theta) \sin \phi] = E_0 \sin \omega t$$

$$\text{or } q_0 \omega Z \cos(\omega t + \theta - \phi) = E_0 \sin \omega t = E_0 \cos(\omega t - \pi/2) \quad \dots(7)$$

Comparing the two sides of this equation, we find that $E_0 = q_0 \omega Z = I_0 Z$, where $I_0 q_0 \omega$... (8)

$$\text{and } \omega t + \theta - \phi = \omega t - \pi/2$$

$$\therefore \theta - \phi = \frac{-\pi}{2}$$

$$\text{or } \theta = \frac{-\pi}{2} + \phi \quad \dots(9)$$

Current in the circuit is

$$I = \frac{dq}{dt} = \frac{d}{dt} [q_0 \sin(\omega t + \theta)] = q_0 \omega \cos(\omega t + \theta)$$

$$I = I_0 \cos(\omega t + \theta) \quad \{ \text{using (8)} \}$$

Using (9), we get, $I = I_0 \cos(\omega t + \phi - \pi/2)$

$$I = I_0 \sin(\omega t + \phi) \quad \dots(10)$$

$$\text{From (6), } \phi = \tan^{-1} \left(\frac{X_C - X_L}{R} \right) \quad \dots(11)$$

$$\text{As } \cos^2 \phi + \sin^2 \phi = 1$$

$$\therefore \left(\frac{R}{Z} \right)^2 + \left(\frac{X_C - X_L}{Z} \right)^2 = 1$$

$$R^2 + (X_C - X_L)^2 = Z^2$$

$$Z = \sqrt{R^2 + (X_C - X_L)^2} \quad \dots(12)$$

7. A.C. CIRCUIT CONTING RESISTANCE & INDUCTANCE

Let a source of alternating e m f be connected to an ohmic resistance R and a coil of inductance L, in series as shown in figure.

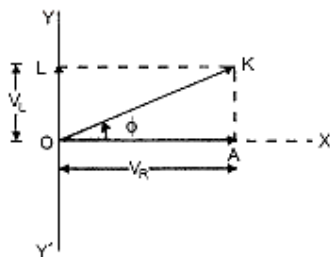
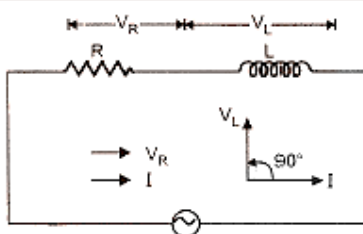

$$Z = \sqrt{R^2 + X_L^2}$$

We find that in RL circuit, voltage leads the current by a phase angle ϕ , where

$$\tan \phi = \frac{AK}{OA} = \frac{OL}{OA} = \frac{V_L}{V_R} = \frac{I_0 X_L}{I_0 R}$$

$$\tan \phi = \frac{X_L}{R}$$

8. A.C. CIRCUIT CONTAINING RESISTANCE AND CAPACITANCE



Let a source of alternating e.m.f. be connected to an ohmic resistance R and a condenser of capacity C , in series as shown in figure.

$$Z = \sqrt{R^2 + X_C^2}$$

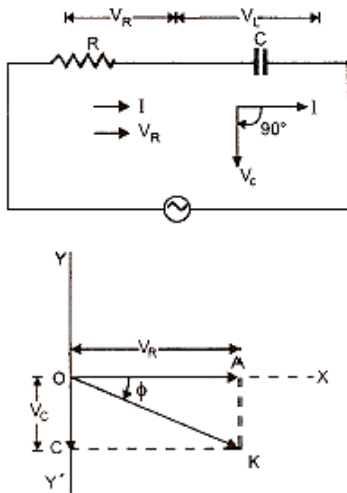

Figure represents phasor diagram of RC circuit. We find that in RC circuit, voltage lags behind the current by a phase angle ϕ , where

$$\tan \phi = \frac{AK}{OA} = \frac{OC}{OA} = \frac{V_C}{V_R} = \frac{I_0 X_C}{I_0 R}$$

$$\tan \phi = \frac{X_C}{R}$$

9. ENERGY STORED IN AN INDUCTOR

When a.c. is applied to an inductor of inductance L , the current in it grows from zero to maximum steady value I_0 . If I is the current at any instant t , then the magnitude of induced e.m.f. developed in the inductor at that instant is,

$$E = L \frac{dI}{dt} \quad \dots(1)$$

The self induced e.m.f. is also called the back e.m.f., as it opposes any change in the current in the circuit.



Physically, the self inductance plays the role of inertia. It is the electromagnetic analogue of mass in mechanics. Therefore, work needs to be done against the back e.m.f. E . in establishing the current. This work done is stored in the inductor as magnetic potential energy.

For the current I at an instant t , the rate of doing work is,

$$\frac{dW}{dt} = EI$$

If we ignore the resistive losses, and consider only inductive effect, then

$$\text{Using (1), } \frac{dW}{dt} = EI = L \frac{dI}{dt} \times I \text{ or } dW = LI dI$$

Total amount of work done in establishing the current I is,

$$W = \int dW = \int_0^I LI dI = \frac{1}{2} LI^2$$

Thus energy required to build up current in an inductor = energy stored in inductor,

$$U_B = W = \frac{1}{2} LI^2$$

10. ELECTRIC RESONANCE

10.1 Series Resonance Circuit

A circuit in which inductance L , capacitance C and resistance R are connected in series, and the circuit admits maximum current corresponding to a given frequency of a.c., is called series resonance circuit.

The impedance (Z) of an RLC circuit is given by

$$Z = \sqrt{R^2 + \left(\omega L - \frac{1}{\omega C}\right)^2} \quad \dots(1)$$

At very low frequencies, inductive reactance $X_L = \omega L$ is negligible, but capacitive reactance ($X_C = 1/\omega C$) is very high.

As frequency of alternating e.m.f. applied to the circuit is increased, X_L goes on increasing and X_C goes on decreasing. For a particular value of $\omega (= \omega_r, \text{ say })$

$$X_L = X_C$$

$$\text{i.e., } \omega_r L = \frac{1}{\omega_r C} \text{ or } \omega_r = \frac{1}{\sqrt{LC}}$$

$$2\pi\nu_r = \frac{1}{\sqrt{LC}} \text{ or } \nu_r = \frac{1}{2\pi\sqrt{LC}}$$

At this particular frequency ν_r as $X_L = X_C$, therefore, from (1)

$$Z = \sqrt{R^2 + 0} = R = \text{minimum}$$

i.e. impedance of RLC circuit is minimum and hence the current $I_0 = \frac{E_0}{Z} = \frac{E_0}{R}$ becomes maximum. This frequency is called series resonance frequency.

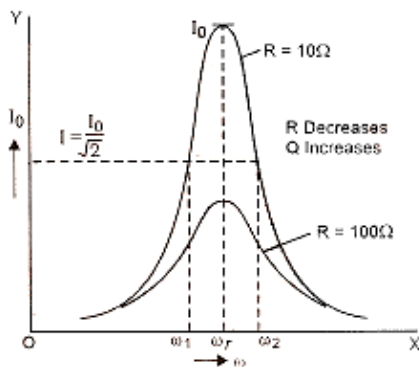

The Q factor of series resonant circuit is defined as the ratio of the voltage developed across the inductance or capacitance at resonance to the impressed voltage, which is the voltage applied across R .

i.e.,



$$\text{i.e. } Q = \frac{\text{voltage across } L \text{ or } C}{\text{applied voltage (= voltage across } R \text{)}}$$

$$Q = \frac{(\omega_r L)I}{RI} = \frac{\omega_r L}{R}$$

$$\text{or } Q = \frac{(1/\omega_r C)I}{RI} = \frac{I}{RC\omega_r}$$

Using $\omega_r = \frac{1}{\sqrt{LC}}$, we get

$$Q = \frac{L}{R} \frac{1}{\sqrt{LC}} = \frac{1}{R} \sqrt{\frac{L}{C}}$$

$$\text{or } Q = \frac{1\sqrt{LC}}{RC} = \frac{1}{R} \sqrt{\frac{L}{C}}$$

$$\text{Thus } Q = \frac{1}{R} \sqrt{\frac{L}{C}} \quad \dots(1)$$

The quantity $\left(\frac{\omega_r}{2\Delta\omega}\right)$ is regarded as a measure of sharpness of resonance, i.e., Q factor of resonance circuit is the ratio of resonance angular frequency to band width of the circuit (which is difference in angular frequencies at which power is half the maximum power or current is $I_0/\sqrt{2}$).

10.2 Average Power in RLC circuit or Inductive Circuit

Let the alternating e.m.f. applied to an RLC circuit be,

$$E = E_0 \sin \omega t \quad \dots(1)$$

If alternating current developed lags behind the applied e.m.f. by a phase angle ϕ , then

$$I = I_0 \sin(\omega t - \phi) \quad \dots(2)$$

Power at instant t , $\frac{dW}{dt} = EI$

$$\frac{dW}{dt} = E_0 \sin \omega t \times I_0 \sin(\omega t - \phi)$$

$$= E_0 I_0 \sin \omega t (\sin \omega t \cos \phi - \cos \omega t \sin \phi)$$

$$= E_0 I_0 \sin^2 \omega t \cos \phi - E_0 I_0 \sin \omega t \cos \omega t \sin \phi$$

$$= E_0 I_0 \sin^2 \omega t \cos \phi - \frac{E_0 I_0}{2} \sin 2\omega t \sin \phi$$

If this instantaneous power is assumed to remain constant for a small time dt , then small amount of work done in this time is.

$$dW = \left(E_0 I_0 \sin^2 \omega t \cos \phi - \frac{E_0 I_0}{2} \sin 2\omega t \sin \phi \right) dt$$

Total work done over a complete cycle is

$$W = \int_0^T E_0 I_0 \sin^2 \omega t \cos \phi dt - \int_0^T \frac{E_0 I_0}{2} \sin 2\omega t \sin \phi dt$$

$$W = E_0 I_0 \cos \phi \int_0^T \sin^2 \omega t dt - \frac{E_0 I_0}{2} \sin \phi \int_0^T \sin 2\omega t dt$$

As $\int_0^T \sin^2 \omega t dt = \frac{T}{2}$ and $\int_0^T \sin \omega t dt = 0$

$$\therefore W = E_0 I_0 \cos \phi \times \frac{T}{2}$$

\therefore Average power in the inductive circuit over a complete cycle.

$$P = \frac{W}{T} = \frac{E_0 I_0 \cos \phi}{T} \cdot \frac{T}{2} = \frac{E_0}{\sqrt{2}} \frac{I_0}{\sqrt{2}} \cos \phi$$

$$P = E_v I_v \cos \phi \quad \dots(3)$$



Hence average power over a complete cycle in an inductive circuit is the product of virtual e.m.f., virtual current and cosine of the phase angle between the voltage and current.

Note.

The relation (3) is applicable to all a.c. circuits. $\cos \phi$ and Z will have appropriate values for different circuits.

For example:

(i) In PL circuit, $Z = \sqrt{R^2 + X_L^2}$ and $\cos \phi = \frac{R}{Z}$

(ii) In RC circuit, $Z = \sqrt{R^2 + X_C^2}$ and $\cos \phi = \frac{R}{Z}$

(iii) In LC circuit, $Z = X_L - X_C$ and $\phi = \{90^\circ\}$

(iv) In RLC circuit, $Z = \sqrt{R^2 + (X_L - X_C)^2}$ and $\cos \phi = \frac{R}{Z}$

In all a.c. circuits, $I_v = \frac{E_v}{Z}$

10.3 Power Factor of an A.C. Circuit

We have proved that average power/cycle in an inductive circuit is

$$P = E_v I_v \cos \phi \quad \dots(1)$$

Here, P is called true power, (E_v, I_v) is called apparent power or virtual power and $\cos \phi$ is called power factor of the circuit.

$$\text{Thus, Power factor} = \frac{\text{true power (P)}}{\text{apparent power (E}_v I_v)} = \cos \phi \quad \dots(2)$$



$$= \frac{R}{\sqrt{R^2 + (X_L - X_C)^2}} \quad [\text{from impedance triangle}]$$

$$\text{Power factor} = \cos \phi = \frac{\text{Resistance}}{\text{Impedance}}$$

In a non-inductance circuit, $X_L = X_C$

$$\therefore \text{Power factor} = \cos \phi = \frac{R}{\sqrt{R^2}} = \frac{R}{R} = 1, \phi = 0^\circ$$

This is the maximum value of power factor. In a pure inductor or an ideal capacitor, $\phi = 90^\circ$.

$$\text{Power factor} = \cos \phi = \cos 90^\circ = 0.$$

Average power consumed in a pure inductor or ideal a capacitor, $P = E_v I_y \cos 90^\circ =$ Zero. Therefore, current through pure L or pure C, which consumes no power for its maintenance in the circuit is called Idle current or Watt less current.

In actual practice, we do not have ideal inductor or ideal capacitor. Therefore, there does occur some dissipation of energy. However, inductance and capacitance continue to be most suitable for controlling current in a.c. circuits with minimum loss of power.

11. A.C. GENERATOR OR A.C. DYNAMO

An a.c. generator/dynamo is a machine which produces alternating current energy from mechanical energy. It is one of the most important applications of the phenomenon of electromagnetic induction. The generator was designed originally by a Yugoslav scientist, Nikola Tesla. The word generator is a misnomer, because nothing is generated by the machine. In fact, it is an alternator converting one form of energy into another.

11.1 Principle

An a.c. generator/dynamo is based on the phenomenon of electromagnetic induction, i.e., whenever amount of magnetic flux linked with a coil changes, an



e.m.f. is induced in the coil. It lasts so long as the change in magnetic flux through the coil continues. The direction of current induced is given by Fleming's right hand rule.

11.2 Construction

The essential parts of an a.c. dynamo are shown in figure.

1. Armature: ABCD is a rectangular armature coil. It consists of a large number of turns of insulated copper wire wound over a laminated soft iron core, I. The coil can be rotated about the central axis.

2. Field Magnets: N and S are the pole pieces of a strong electromagnet in which the armature coil is rotated. Axis of rotation is perpendicular to the magnetic field lines. The magnetic field is of the order of 1 to 2 tesla.

3. Slip Rings: R_1 and R_2 are two hollow metallic rings, to which two ends of armature coil are connected. These rings rotate with the rotation of the coil.

4. Brushes: B_1 and B_2 are two flexible metal plates or carbon rods. They are fixed and are kept in light contact with R_1 and R_2 respectively. The purpose of brushes is to pass on current from the armature coil to the external load in resistance R .

Theory and Working: As the armature coil is rotated in the magnetic field, angle θ between the field and normal to the coil changes continuously. Therefore, magnetic flux linked with the coil changes. An e.m.f. is induced in the coil.

To start with, suppose the plane of the coil is perpendicular to the plane of the paper in which magnetic field is applied, with AB at front and CD at the back, figure (a). The amount of magnetic flux linked with the coil in this position is maximum. As the coil is rotated anticlockwise (or clockwise), AB moves inwards and CD moves outwards. The amount of magnetic flux linked with the coil changes. According to Fleming's right hand rule, current induced in AB is from A to B and in CD, it is from C to D. In the external circuit, current flows from B_2 to B_1 , figure (a).

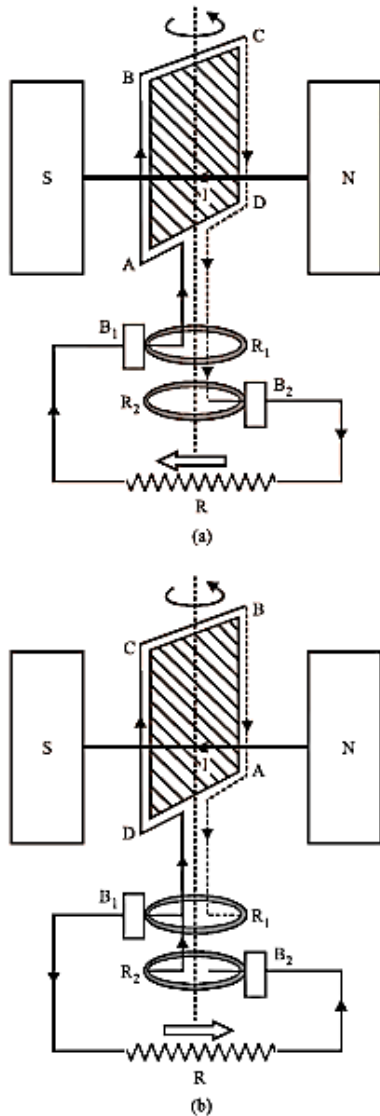

After half the rotation of the coil, AB is at the back and CD is at the front, figure. Therefore, on rotating further, AB moves outwards and CD moves outwards and CD moves inwards. The current induced in AB is from B to A and in CD, it is from D to C. Through external circuit, current flows from B₁ to B₂; figure (b). This is repeated. Induced current in the external circuit changes direction after every half rotation of the coil. Hence the current induced is alternating in nature.

To calculate the magnitude of e.m.f. induced, suppose

N = number of turns in the coil,

A = area enclosed by each turn of the coil



\vec{B} = strength of magnetic field

θ = angle which normal to the coil makes with \vec{B} at any instant t , figure.

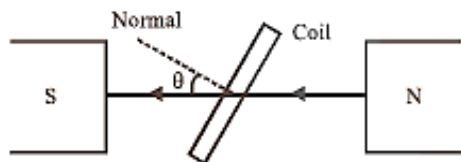

Magnetic flux linked with the coil in this position

$$\phi = N(\vec{B} \cdot \vec{A}) = NBA \cos \theta = NBA \cos \omega t \quad \dots(1)$$

where ω is angular velocity of the coil.

As the coil is rotated, θ changes; therefore, magnetic flux ϕ linked with the coil changes and hence an e.m.f. is induced in the coil.

At the instant t , if e is the e.m.f. induced in the coil, then

$$e = \frac{-d\phi}{dt} = -\frac{d}{dt}(NAB \cos \omega t)$$

$$e = -NAB \frac{d}{dt}(\cos \omega t) = -NAB(-\sin \omega t)\omega$$

$$E = NAB\omega \sin \omega t \quad \dots(2)$$

The induced e.m.f. will be maximum, when

$$\sin \omega t = \text{maximum} = 1$$

$$e_{\text{max}} = e_0 = NAB\omega \times 1 \quad \dots(3)$$

$$\text{Put in (2), } e = e_0 \sin \omega t \quad \dots(4)$$

The variation of induced e.m.f. with time (i.e. with position of the coil) is shown in figure.

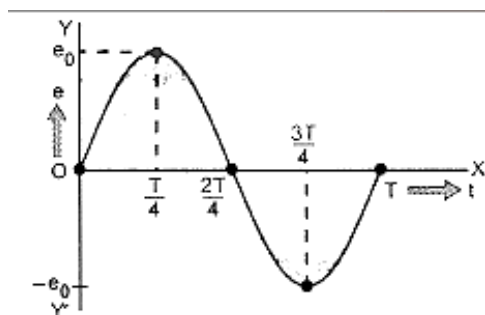

Note.

Suppose to start with, the plane of the coil is not perpendicular to the magnetic field. Therefore, at $t=0$ $\theta \neq 0$. Let $\theta = \delta$, the phase angle. This is the angle which normal to the coil makes with the direction of \vec{B} . The equation (4) of e.m.f. induced in that case can be rewritten as $e = e_0 \sin(\omega t + \delta)$.

12. TRANSFORMER

A transformer which increases the a.c. voltage is called a step up transformer. A transformer which decreases the a.c. voltages is called a step down transformer.

12.1 Principle

A transformer is based on the principle of mutual induction, i.e., whenever the amount of magnetic flux linked with a coil changes, an e.m.f. is induced in the neighbouring coil.

12.2 Construction

A transformer consists of a rectangular soft iron core made of laminated sheets, well insulated from one another, figure. Two coils P_1P_2 (the primary coil) and S_1S_2 (the secondary coil) are wound on the same core, but are well insulated from each other. Note that both the coils are also insulated from the core. The source of alternating e.m.f. (to be transformed) is connected to the primary coil P_1P_2 and a load resistance R is connected to the secondary coil S_1S_2 through an open switch S . Thus, there can be no current through the secondary coil so long as the switch is open.

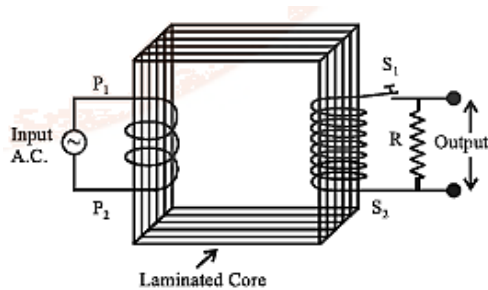

For an ideal transformer, we assume that the resistances of the primary and secondary windings are negligible.

Further, the energy losses due to magnetic hysteresis in the iron core is also negligible. Well-designed high capacity transformers may have energy losses as low as 1% .

12.3 Theory and working

Let the alternating e.m.f. supplied by the a.c. source connected to primary be

$$E_p = E_0 \sin \omega t \quad \dots(1)$$

As we have assumed the primary to be a pure inductance with zero resistance, the sinusoidal primary current I_p lags the primary voltage E_p by $\{90^\circ\}$. The primary's power factor, $\cos \phi = \{90^\circ\} = 0$. Therefore, no power is dissipated in primary.

The alternating primary current induces an alternating magnetic flux ϕ_B in the iron core. Because the core extends through the secondary winding, the induced flux also extends through the turns of secondary.

According to Faraday's law of electromagnetic induction. the induced e.m.f. per turn (E_{turn}) is same for both, the primary and secondary. Also, the voltage E_p across the primary is equal to the e.m.f. induced in the primary, and the voltage E_s across the secondary is equal to the e.m.f. induced in the secondary. Thus,

$$E_{\text{turn}} = \frac{d\phi_B}{dt} = \frac{E_p}{n_p} = \frac{E_s}{n_s}$$



Here, $n_p; n_s$ represent total number of turns in primary and secondary coils respectively-

$$E_s = E_p \frac{n_s}{n_p} \quad \dots(2)$$

If $n_s > n_p; E_s > E_p$, the transformer is a step up transformer. Similarly, when $n_s < n_p; E_s < E_p$. The device is called a step down transformer. $\frac{n_s}{n_p} = K$ represents transformation ratio.

Note that this relation (2) is based on three assumptions

- (i) the primary resistance and current are small,
- (ii) there is no leakage of magnetic flux. The same magnetic flux links both, the primary and secondary coil,
- (iii) the secondary current is small.

Now, the rate at which the generator/source transfer energy to the primary = $I_p E_p$. The rate at which the primary then transfers energy to the secondary (via the alternating magnetic field linking the two coils) is $I_s E_s$.

As we assume that no energy is lost along the way, conservation of energy requires that

$$I_p E_p = I_s E_s$$

$$\therefore I_s = I_p \frac{E_p}{E_s}$$

$$\text{From (2), } \frac{E_p}{E_s} = \frac{n_p}{n_s}$$

$$\therefore I_s = I_p \times \frac{n_p}{n_s} = \frac{I_p}{K} \quad \dots(3)$$



For a step up transformer, $E_s > E_p; K > 1 \therefore I_s < I_p$ i.e. secondary current is weaker when secondary voltage is higher, i.e., whatever we gain in voltage, we lose in current in the same ratio.

The reverse is true for a step down transformer.

$$\text{From eqn. (3) } I_p = I_s \left(\frac{n_s}{n_p} \right) = \frac{E_s}{R} \left(\frac{n_s}{n_p} \right)$$

$$\text{Using equation (2), we get } I_p = \frac{1}{R} \cdot E_p \left(\frac{n_s}{n_p} \right) \left(\frac{n_s}{n_p} \right)$$

$$I_p = \frac{1}{R} \left(\frac{n_s}{n_p} \right)^2 E_p \quad \dots(4)$$

This equation, has the form $I_p = \frac{E_p}{R_{eq}}$, where the equivalent resistance R_{eq} is

$$R_{eq} = \left(\frac{n_p}{n_s} \right)^2 R \quad \dots(5)$$

Thus R_{eq} is the value of load resistance as seen by the source/generator, i.e., the source/generator produces current I_p and voltage E_p as if it were connected to a resistance R_{eq}^{-1}

Efficiency of a transformer is defined as the ratio of output to the input power.

$$\text{i.e., } \eta = \frac{\text{Output power}}{\text{Input power}} = \frac{E_s I_s}{E_p I_p}$$

In an ideal transformer, where there is no power loss, $\eta = 1$ (i.e. 100%). However, practically there are many energy losses. Hence efficiency of a transformer in practice is less than one (i.e. less than 100%).

12.4 Energy Losses in a Transformer

Following are the major sources of energy loss in a transformer:



1. Copper loss is the energy loss in the form of heat in the copper coils of a transformer. This is due to Joule heating of conducting wires. These are minimized using thick wires.
2. Iron loss is energy loss in the form of heat in the iron core of the transformer. This is due to formation of eddy currents in iron core. It is minimised by taking laminated cores.
3. Leakage of magnetic flux occurs in spite of best insulations. Therefore, rate of change of magnetic flux linked with each turn of $S_1 S_2$ is less than the rate of change of magnetic flux linked with each turn of $P_1 P_2$. It can be reduced by winding the primary and secondary coils one over the other.
4. Hysteresis loss. This is the loss of energy due to repeated magnetisation and demagnetisation of the iron core when a.c. is fed to it. The loss is kept to a minimum by using a magnetic material which has a low hysteresis loss.
5. Magnetostriction, i.e., humming noise of a transformer.

Therefore, output power in the best transformer may be roughly 90% of the input power.

13. DISPLACEMENT CURRENT

According to Ampere circuital law:

the line integral of magnetic field \vec{B} around any closed path is equal to μ_0 times the total current threading the closed path, i.e.,

$$\oint_C \vec{B} \cdot d\vec{\ell} = \mu_0 I \quad \dots(1)$$

Consider a parallel plate capacitor having plates P and Q connected to a battery B, through a tapping key K. When key K is pressed, the conduction current flows through the connecting wires. The capacitor starts storing charge. As the charge on the capacitor grows, the conduction current in the wires decreases. When the capacitor is fully charged, the conduction current stops flowing in the wires. During charging of capacitor, there is no conduction current between the plates of capacitor. During charging, let at an instant, I be the conduction current in the

wires. This current will produce magnetic field around the wires which can be detected by using a compass needle.

Let us find the magnetic field at point R which is at a perpendicular distance r from connecting wire in a region outside the parallel plate capacitor. For this we consider a plane circular loop C_1 , of radius r , whose centre lies on wire and its plane is perpendicular to the direction of current carrying wire (figure a). The magnitude of the magnetic field is same at all points on the loop and is acting tangentially along the circumference of the loop. If B is the magnitude of magnetic field at R , then using Ampere's circuital law, for loop C_1 , we have

$$\oint_{C_1} \vec{B} \cdot d\vec{l} = \oint_{C_1} B dl \cos 0^\circ = B2\pi r = \mu_0 I \text{ or } B = \frac{\mu_0 I}{2\pi r} \quad \dots(2)$$

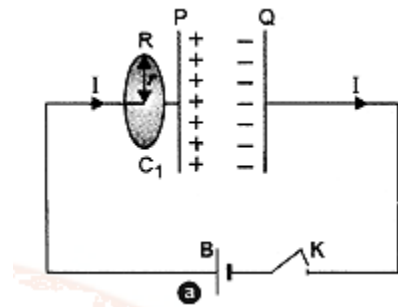

Now, we consider a different surface, i.e., a tiffin box shaped surface without lid with its circular rim, which has the same boundary as that of loop C_1 . The box does not touch to the connecting wire and plate P of capacitor. The flat circular bottom S of the tiffin box lies in between the capacitor plates. Figure (b). No conduction current is passing through the tiffin box surface S , therefore $I=0$. On applying Ampere's circuital law to loop C_1 of this tiffin box surface, we have

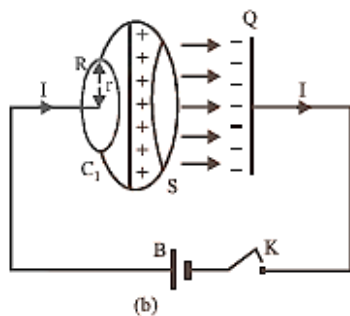

$$\oint_C \vec{B} \cdot d\vec{l} = B2\pi r = \mu_0 \times 0 = 0 \text{ or } B = 0 \quad \dots(3)$$



From (2) and (3), we note that there is a magnetic field at R , calculated through one way and no magnetic field at R , calculated through another way. Since this contradiction arises from the use of Ampere's circuital law, hence Ampere's circuital law is logically inconsistent.

If at the given instant of time, q is the charge on the plate of capacitor and A is the plate area of capacitor, the magnitude of the electric field between the plates of capacitor is

$$E = \frac{q}{\epsilon_0 A}$$

This field is perpendicular to surface S . It has the same magnitude over the area A of the capacitor plates and becomes zero outside the capacitor.

The electric flux through surface S is,

$$\dots(4)$$

If $\frac{dq}{dt}$ is the rate of change of charge with time on the plate of the capacitor, then

or

Here, $\frac{dq}{dt}$ = current through surface S corresponding to changing electric field = I_D , called Maxwell's displacement current. Thus,

displacement current is that current which comes into play in the region in which the electric field and the electric flux is changing with time.

Maxwell modified Ampere's circuital law in order to make the same logically consistent. He stated Ampere's circuital law to the form.

$$\oint \vec{B} \cdot d\vec{\ell} = \mu_0 (I + I_D) = \mu_0 \left(I + \epsilon_0 \frac{d\phi_E}{dt} \right) \quad \dots(6)$$

This is called Ampere Maxwell's Law.



14. CONTINUITY OF CURRENT

Maxwell's modification of Ampere's circuital law gives that $\oint_C \vec{B} \cdot d\vec{\ell} = \mu_0 (I + I_D)$

where I_D , called displacement current, I is the conduction current and ϕ_E is the electric flux across the loop C .

The sum of the conduction current and displacement current (i.e., $I + I_D$) has the important property of continuity along any closed path although individually they may not be continuous.

To prove it, consider a parallel plate capacitor having plates P and Q , being charged with battery B . During the time, charging is taking place, let at an instant, I be the conduction current flowing through the wires. Let C_1 and C_2 be the two loops, which have exactly the same boundary as that of the plates of capacitor. C_1 is little towards left and C_2 is a little towards right of the plate P of parallel plate capacitor, figure.

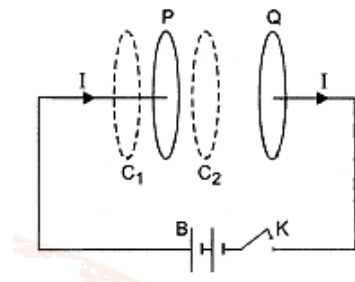

Due to battery B , let the conduction current I be flowing through the lead wires at any instant, but there is no conduction current across the capacitor gap, as no charge is transported across this gap.

For loop C_1 , there is no electric flux, i.e., $\phi_E = 0$ and

For loop C_2 , there is no conduction current, i.e., $I = 0 \dots (8)$



At the given instant if q is the magnitude of charge on the, plates of the capacitor of area A , then electric field E in the gap between the two plates of this capacitor is given by

\therefore Electric flux,

Thus from (8), we have ... (9)

From (7) and (9), we conclude that the sum $(I + I_D)$ has the same value on the left and right side of plate P of the parallel plate capacitor. Hence $(I + I_D)$ has the property of continuity although individually they may not be continuous.

15. CONSEQUENCES OF DISPLACEMENT CURRENT

The discovery of displacement current is of great importance as it has established a symmetry between the laws of electricity and magnetism. Faraday's law of electromagnetic induction states that the magnitude of the emf induced in a coil is equal to the rate of change of magnetic flux linked with it. Since, the emf between two

points A and B is the measure of maximum work done in taking a unit charge from point A to B , therefore, the existence of an emf shows the existence of an electric field. It is due to this fact, Faraday concluded that a changing magnetic field with time gives rise to an electric field.

The Maxwell's concept that a changing electric field with time gives rise to displacement current which also produces a magnetic field similar to that of conduction current. It is in fact, a symmetrical counterpart of the Faraday's concept, which led Maxwell to conclude that the displacement current is also a source of magnetic field. It means the time varying electric and magnetic fields give rise to each other. From these concepts, Maxwell concluded the existence of electromagnetic wave in a region where electric and magnetic fields were changing with time.

16. MAXWELL'S EQUATIONS AND LORENTZ FORCE



In the absence of any dielectric or magnetic material, the four Maxwell's equations are given below?

(i) . This equation is Gauss's Law in electrostatics.

The electric lines of force do not form continuous closed path.

(ii) $\oint_s \vec{B} \cdot d\vec{s} = 0$. This equation is Gauss's Law in magnetostatics.

The magnetic lines of force always form closed paths.

(iii) $\oint \vec{E} \cdot d\vec{\ell} = -\frac{d}{dt} \int \vec{B} \cdot d\vec{s}$. This equation is Faraday's law of electromagnetic induction.

The line integral of electric field around any closed path (i.e., the emf) is equal to the time rate of change of magnetic flux through the surface bounded by the closed path.

(iv) $\oint \vec{B} \cdot d\vec{\ell} = \mu_0 I + \mu_0 \epsilon_0 \frac{d}{dt} \int \vec{E} \cdot d\vec{s}$. This equation is generalised form of Ampere's law as Modified by Maxwell and is also known as Ampere-Maxwell law.

The electromagnetic waves are those wave in which there are sinusoidal variation of electric and magnetic field vectors at right angles to each other as well as at right angles to the direction of wave propagation.

$$c = \frac{1}{\sqrt{\mu_0 \epsilon_0}} \quad \dots(10)$$

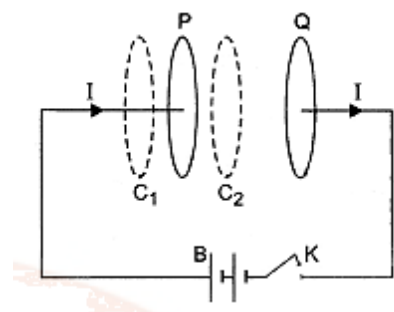

where μ_0 and ϵ_0 are permeability and permittivity of the free space respectively-



We know, $\mu_0 = 4\pi \times 10^{-7} \text{ Wb A}^{-1} \text{ m}^{-1}$

Putting these values in (10), we have $c = 3.00 \times 10^8 \text{ ms}^{-1}$ where μ and ϵ are the absolute permeability and absolute permittivity of the medium. We also know that $\mu = \mu_0 \mu_r$ and $\epsilon = \epsilon_0 \epsilon_r$ where μ_r and ϵ_r are the relative permeability and relative permittivity of the medium.

$$\text{Therefore, } v = \frac{1}{\sqrt{\mu_0 \mu_r \epsilon_0 \epsilon_r}} = \frac{c}{\sqrt{\mu_r \epsilon_r}} \quad \left[\because c = \frac{1}{\sqrt{\mu_0 \epsilon_0}} \right]$$

Maxwell also concluded that electromagnetic wave is transverse in nature and light is electromagnetic wave.

17. VELOCITY OF ELECTROMAGNETIC WAVES

Consider a plane electromagnetic wave propagating along positive direction of X-axis in space with speed c . Since in electromagnetic wave, the electric and magnetic fields are transverse to the direction of wave propagation, therefore, the electric and magnetic fields are in Y-Z plane.

Let the electric field \vec{E} be acting along Y-axis and magnetic field \vec{B} along Z-axis.

At any instant, the electric and magnetic fields varying sinusoidally with x and t can be represented by the equations.

$$E = E_y = E_0 \sin \omega(t - x/c) \quad \dots(1)$$

$$B = B_z = B_0 \sin \omega(t - x/c) \quad \dots(2)$$

Here E_0 and B_0 are the amplitudes of electric and magnetic fields along Y-axis and Z-axis respectively. Consider a rectangular path PQRS in X - Y plane as shown in figure.

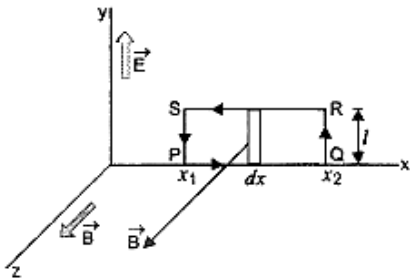

The line integral of \vec{E} over the closed path PQRS will be

$$\begin{aligned} \oint_{PQRS} \vec{E} \cdot d\vec{l} &= \int_P^Q \vec{E} \cdot d\vec{l} + \int_Q^R \vec{E} \cdot d\vec{l} + \int_R^S \vec{E} \cdot d\vec{l} + \int_S^P \vec{E} \cdot d\vec{l} \\ &= 0 + E_{(x_2)}l + 0 + E_{(x_1)}(-l) \\ &= E_0 l \left[\sin \omega \left(t - \frac{x_2}{c} \right) - \sin \omega \left(t - \frac{x_1}{c} \right) \right] \quad \dots(3) \end{aligned}$$

Magnetic flux linked with surface surrounded by rectangular path PQRS will be

$$\begin{aligned} \phi_B &= \int_{x_1}^{x_2} B(x)l dx = \int_{x_1}^{x_2} B_0 l \left[\sin \omega \left(t - \frac{x}{c} \right) \right] dx \\ &= \frac{B_0 l c}{\omega} \left[\cos \omega \left(t - \frac{x_2}{c} \right) - \cos \omega \left(t - \frac{x_1}{c} \right) \right] \\ \frac{d\phi_B}{dt} &= \frac{B_0 l c}{\omega} \left[-\omega \sin \omega \left(t - \frac{x_2}{c} \right) + \omega \sin \omega \left(t - \frac{x_1}{c} \right) \right] \\ &= -B_0 l c \left[\sin \omega \left(t - \frac{x_2}{c} \right) - \sin \omega \left(t - \frac{x_1}{c} \right) \right] \quad \dots(4) \end{aligned}$$

Using Faraday's law of electromagnetic induction, we have

$$\oint \vec{E} \cdot d\vec{l} = -\frac{d\phi_B}{dt}$$

Putting the values from (3) and (4), we get



$$E_0 = cB_0 \quad \dots(5)$$

Since E and B are in phase, we can write.

$E = c B$ at any point in space.

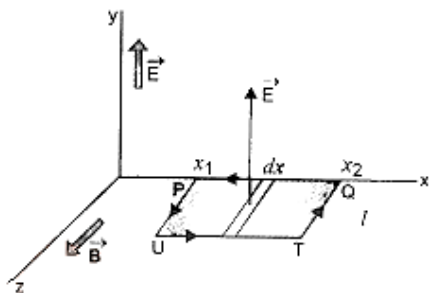

Consider a rectangular path PUTQ in the X–Z plane as shown in figure. The line integral of \vec{B} over the closed path PUTQ, we have

$$\begin{aligned} \oint_{\text{PUTQ}} \vec{B} \cdot d\vec{\ell} &= \int_P^U \vec{B} \cdot d\vec{\ell} + \int_U^T \vec{B} \cdot d\vec{\ell} + \int_T^Q \vec{B} \cdot d\vec{\ell} + \int_Q^P \vec{B} \cdot d\vec{\ell} \\ &= B_{(x_1)}\ell + 0 - B_{(x_2)}\ell + 0 \\ &= B_0\ell \left[\sin \omega \left(t - \frac{x_1}{c} \right) - \sin \omega \left(t - \frac{x_2}{c} \right) \right] \quad \dots(6) \end{aligned}$$

The electric flux linked with the surface surrounded by rectangular path PUTQ is

$$\begin{aligned} \phi_E &= \int_{x_1}^{x_2} \vec{E} \cdot d\vec{s} = \int_{x_1}^{x_2} E(x)\ell dx = E_0\ell \int_{x_1}^{x_2} \sin \omega \left(t - \frac{x}{c} \right) dx \\ &= -\frac{c}{\omega} E_0\ell \left[-\cos \omega \left(t - \frac{x_2}{c} \right) + \cos \omega \left(t - \frac{x_1}{c} \right) \right] \\ \frac{d\phi_E}{dt} &= -cE_0\ell \left[\sin \omega \left(t - \frac{x_2}{c} \right) - \sin \omega \left(t - \frac{x_1}{c} \right) \right] \\ &= cE_0\ell \left[\sin \omega \left(t - \frac{x_1}{c} \right) - \sin \omega \left(t - \frac{x_2}{c} \right) \right] \quad \dots(7) \end{aligned}$$



In space, there is no conduction current. According to Ampere Maxwell law in space

$$\oint_{\text{PUTQ}} \vec{B} \cdot d\vec{\ell} = \mu_0 \epsilon_0 \frac{d\phi_E}{dt}$$

Putting values from (6) and (7), we get

$$B_0 = \mu_0 \epsilon_0 c E_0 = \mu_0 \epsilon_0 c (c B_0)$$

$$\text{or } 1 = \mu_0 \epsilon_0 c^2 \quad \text{or } c = \frac{1}{\sqrt{\mu_0 \epsilon_0}} \quad \dots(8)$$

Which is the speed of electromagnetic waves in vacuum. For vacuum, $\mu_0 = 4\pi \times 10^{-7} \text{ T m A}^{-1}$ and $\frac{1}{\pi \epsilon_0} = 9 \times 10^9 \text{ Nm}^2 \text{C}^{-2}$

Putting the value in (8), we get

$$c = \frac{1}{\sqrt{\pi \times 10^{-7} \times 1 / (\pi \times 9 \times 10^9)}} = 3 \times 10^8 \text{ m/s}$$

which is exactly the speed of light in vacuum.

This shows that light is an electromagnetic wave.

18. INTENSITY OF ELECTROMAGNETIC WAVE

Intensity of electromagnetic wave at a point is defined as the energy crossing per second per unit area normally around that point during the propagation of electromagnetic wave.

Consider the propagation of electromagnetic wave with speed c along the X-axis. Take an imaginary cylinder of area of cross-section A and length $c \Delta t$, so that the wave crosses the area A normally. Figure. Let u_{av} be the average energy density of electromagnetic wave.

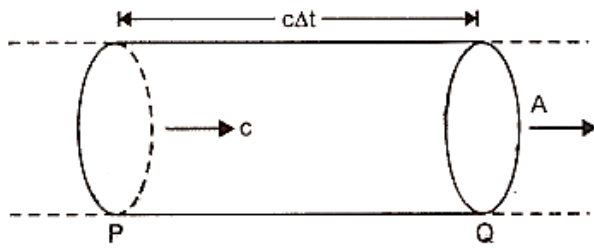

The energy of electromagnetic wave (U) crossing the area of cross-section at P normally in time Δt is the energy of wave contained in a cylinder of length $c\Delta t$ and area of cross-section A . It is given by $U = u_m(c\Delta t)A$. The intensity of electromagnetic wave at P is,

$$I = \frac{U}{A\Delta t} = \frac{u_w c\Delta t A}{A\Delta t} = u_{av} c$$

In terms of maximum electric field, $u_{av} = \frac{1}{2} \epsilon_0 E_0^2$

so .

In terms of maximum magnetic field, $u_{av} = \frac{1}{2} \frac{B_0^2}{\mu_0}$,

$$\text{so } I = \frac{1}{2} \frac{B_0^2}{\mu_0} c = \frac{1}{\mu_0} B_{rms}^2 c.$$

19. ELECTROMAGNETIC SPECTRUM

After the experimental discovery of electromagnetic waves by Hertz, many other electromagnetic waves were discovered by different ways of excitation.

The orderly distribution of electromagnetic radiations according to their wavelength or frequency is called the electromagnetic spectrum.

The electromagnetic spectrum has much wider range with wavelength variation $\backslash 10^{-14}$ m to 6×10^2 m. The whole electromagnetic spectrum has been classified into different parts and subparts in order of increasing wavelength, according to their



type of excitation. There is overlapping in certain parts of the spectrum, showing that the corresponding radiations can be produced by two methods. It may be noted that the physical properties of electromagnetic waves are decided by their wavelengths and not by the method of their excitation.

A table given below shows the various parts of the electromagnetic spectrum with approximate wavelength range, frequency range, their sources of production and detections.

20. MAIN PARTS OF ELECTROMAGNETIC SPECTRUM

The electromagnetic spectrum has been broadly classified into following main parts; mentioned below in the order of increasing frequency.

20.1 Radiowaves

These are the electromagnetic wave of frequency range from 5×10^5 Hz to 10^9 Hz. These waves are produced by oscillating electric circuits having an inductor and capacitor.

Uses: The various frequency ranges are used for different types of wireless communication systems as mentioned below

- (i) The electromagnetic waves of frequency range from 530 kHz to 1710kHz form **amplitude modulated (AM) band**. It is used in ground wave propagation.
- (ii) The electromagnetic waves of frequency range 1710kHz to 54Mhz are used for **short wave bands**. It is used in sky wave propagation.
- (iii) The electromagnetic waves of frequency range 54Mhz to 890MHz are used in **television waves**.
- (iv) The electromagnetic waves of frequency range 88MHz to 108MHz form **frequency modulated (FM) radio band**. It is used for **commercial FM radio**.
- (v) The electromagnetic waves of frequency range 300MHz to 3000MHz form **ultra high frequency (UHF) band**. It is used in cellular phones communication.



20.2 Microwaves

Microwaves are the electromagnetic waves of frequency range 1GHz to 300GHz. They are produced by special vacuum tubes. namely; klystrons, magnetrons and Gunn diodes etc.

Uses:

- (i) Microwaves are used in Radar systems for air craft navigation.
- (ii) A radar using microwave can help in detecting the speed of tennis ball, cricket ball, automobile while in motion.
- (iii) Microwave ovens are used for cooking purposes.
- (iv) Microwaves are used for observing the movement of trains on rails while sitting in microwave operated control rooms.

20.3 Infrared waves

Infrared waves were discovered by Herschell. These are the electromagnetic waves of frequency range 3×10^{11} Hz to 4×10^{14} Hz. **Infrared waves sometimes are called as heat waves.** Infrared waves are produced by hot bodies and molecules. These wave are not detected by human eye but snake can detect them.

Uses:

Infrared waves are used:

- (i) in physical therapy, i.e., to treat muscular strain.
- (ii) to provide electrical energy to satellite by using solar cells
- (iii) for producing dehydrated fruits
- (iv) for taking photographs during the condition of fog, smoke etc.
- (v) in green houses to keep the plants warm
- (vi) in revealing the secret writings on the ancient walls



(vii) in solar water heaters and cookers

(viii) in weather forecasting through infrared photography

(ix) in checking the purity of chemicals and in the study of molecular structure by taking infrared absorption spectrum.

20.4 Visible light

It is the narrow region of electromagnetic spectrum, which is detected by the human eye. Its frequency is ranging from 4×10^{14} Hz to 8×10^{14} Hz. It is produced due to atomic excitation.

The visible light emitted or reflected from objects around us provides the information about the world surrounding us.

20.5 Ultraviolet rays

The ultraviolet rays were discovered by Ritter in 1801. The frequency range of ultraviolet rays is 8×10^{14} Hz to 5×10^{16} Hz. The ultraviolet rays are produced by sun, special lamps and very hot bodies. Most of the ultraviolet rays coming from sun are absorbed by the ozone layer in the earth's atmosphere. The ultraviolet rays in large quantity produce harmful effect on human eyes.

Uses: Ultraviolet rays are used:

(1) for checking the mineral samples through the property of ultraviolet rays causing fluorescence. electrons in the external shell through ultraviolet absorption spectra.

(iii) to destroy the bacteria and for sterilizing the surgical instruments.

(iv) in burglar alarm.

(v) in the detection of forged documents, finger prints in forensic laboratory-

(vi) to preserve the food stuff.

20.6 X-rays



The X-rays were discovered by German Physicist W. Roentgen. Their frequency range is 10^{16} Hz to 3×10^{21} Hz. These are produced when high energy electrons are stopped suddenly on a metal of high atomic number. X-rays have high penetrating power.

Uses: X-rays are used:

- i) In surgery for the detection of fractures, foreign bodies like bullets, diseased organs and stones in the human body.
- ii) In Engineering (i) for detecting faults, cracks, flaws and holes in final metal products (ii) for the testing of welding, casting and moulds.
- (iii) In Radio therapy, to cure untraceable skin diseases and malignant growth.
- (iv) In detective departments (i) for detection of explosives, opium, gold and silver in the body of smugglers.
- (v) In Industry (i) for the detection of pearls in oysters and defects in rubber tyres, gold and tennis balls etc. (ii) for testing the uniformity of insulating material.
- (vi) In Scientific Research (i) for the investigation of structure of crystal, arrangement of atoms and molecules in the complex substances.

20.7 γ -rays

γ -rays are the electromagnetic waves of frequency range 3×10^{18} Hz to 5×10^{22} Hz. γ -rays have nuclear origin. These rays are highly energetic and are produced by the nucleus of the radioactive substances.

Uses: γ -rays are used:

- (i) in the treatment of cancer and tumours.
- (ii) to preserve the food stuffs for a long time as the soft γ -rays can kill microorganisms easily.
- (iii) to produce nuclear reactions.
- (iv) to provide valuable information about the structure of atomic nucleus.