



Revision Notes

Class – 12 Physics

Chapter 6 – Electromagnetic Induction

1. Magnetic Flux:

(i) The magnetic flux associated with an area placed in a magnetic field is equal to the total number of magnetic lines of force passing naturally through that area.

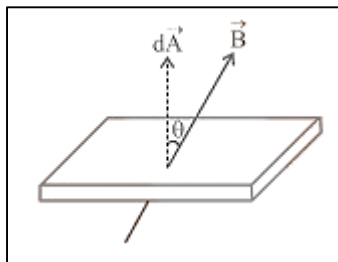

Net flux through the surface $\phi = \oint \vec{B} \cdot d\vec{A} = BA \cos \theta$

(θ is the angle between area vector and magnetic field vector) If $\theta = 0^\circ$ then $\phi = BA$,
If $\theta = 90^\circ$ then $\phi = 0$

(iii) Unit and Dimension : Magnetic flux is a scalar quantity. It's S.I. unit is weber (wb), CGS unit is Maxwell or Gauss $\times cm^2$; ($1wb = 10^8 Maxwell$).

(iv) Other units: $Tesla \times m^2 = \frac{N \times m}{Amp} = \frac{Joule}{Amp} = \frac{Volt \times Coulomb}{Amp}$
= Volt \times sec = Ohm \times Coulomb = Henry \times Amp.

It's dimensional formula, $[\phi] = [ML^2T^{-2}A^{-1}]$

2. Faraday's Laws of Emi:

(i) First law: An induced emf is formed in a circuit whenever the number of magnetic lines of force (magnetic flux) travelling through it changes. The induced emf lasts only as long as the flux is changing or being cut.

(ii) Second law: The induced emf is calculated from the rate of change of



$$e = -\frac{d\phi}{dt} \text{ .For } N \text{ turns } e = -\frac{Nd\phi}{dt} \text{ ; Negative sign}$$

$$= \frac{e^2}{R} = -\frac{1}{R} \cdot \frac{d\phi}{dt}$$

$dq = idt = -\frac{N}{R} \cdot d\phi$	$P = \frac{e^2}{R} = \frac{N^2}{R} \left(\frac{d\phi}{dt} \right)^2$
Induced charge is time independent.	It depends on time and resistance.

Various Methods of Producing induced E.M.F.

We have learnt that e.m.f. is induced in a circuit, whenever the amount of magnetic flux linked with the circuit is changed. As $\phi = BA \cos\theta$, the magnetic flux ϕ can be changed by changing B, A or θ Hence there are three methods of producing induced e.m.f.

- (i) By adjusting the magnetic field B 's magnitude,
- (ii) By altering region A , i.e., shrinking, stretching, or modifying the coil's shape.
- (iii) By changing the angle between the direction of B and the normal to the surface area A , i.e. modifying the surface area's and magnetic field's relative orientation.

3. Lenz's Law:

The induced emf/induced current direction is determined by this law.

The direction of induced emf or current in a circuit, according to this law, is such that it opposes the source that generates it. The law of conservation of energy underpins this rule.

- (i) When the N -pole of a bar magnet advances towards the coil, the flux associated with the loop increases, causing an emf. Induced current flows through

the loop circuit since it is closed.

(ii) Because the approaching north pole is the cause of this induced current, the induced current in the loop is directed in such a way that the front face of the loop behaves like the north pole. Therefore induced current as seen by observer O is in anticlockwise direction. (figure)

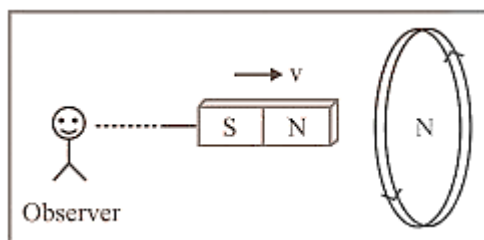

(iii) The cause of generated emf in the coil can also be referred to as relative motion if the loop is free to move. As a result, the relative motion between the two objects works against the cause. The loop and the incoming magnet should be in opposition. As a result, the loop will begin to move in the direction of The magnet is moving.

(iv) It is critical to keep in mind that whenever the reason of induced The new motion is always in the direction of the emf.

Position of magnet				
Direction of induced current	Anticlockwise direction	Clockwise direction	Clockwise direction	Anticlockwise direction
Behavior of face of the coil	As a north pole	As a south pole	As a south pole	As a north pole

Type of magnetic force opposed	Repulsive force	Attractive force	Repulsive force	Attractive force
Magnetic field linked with the coil and it's progresses as viewed from left	Cross(\times), Increases	Cross(\times), Decreases	Cross(\times), Increases	Cross(\times), Decreases

4. Eddy Current:

When a changing magnetic flux is given to a large piece of conducting material, it induces circling currents known as eddy currents. Eddy currents have huge magnitudes and heat up the conductor because the bulk conductor's resistance is usually low.

- (i) These are circulating currents, similar to water eddies.
- (ii) The "Focault current" is named after Focault's experimental hypothesis.
- (iii) In a metallic block, the generation of eddy currents results in the loss of electric energy in the form of heat.
- (iv) As a result of the lamination and slotting processes, the resistance channel for eddy current circulation increases, weakening and lowering them and also reducing losses causes by them.

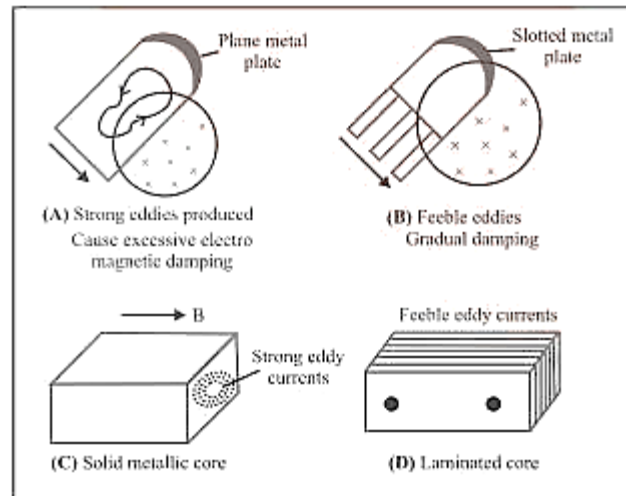

(v) Eddy current applications: Although eddy currents are generally unwelcome, they do have some helpful applications, as listed below.

(iv) Dead-beat galvanometer: When a current is delivered via its coil, a dead beat galvanometer's pointer comes to rest in the final equilibrium position instantaneously, with no oscillation around the equilibrium position.

This is accomplished by winding the coil around a metallic frame, which induces significant eddy currents that give electromagnetic damping.

(i) When the train is running, the wheel moves in the air; when the train is stopped by electric brakes, the wheel is made to move in an electromagnet-created field. Eddy currents created in the wheels as a result of the changing flux work against the cause and bring the train to a halt.

(ii) Induction furnace: The heat of Joule causes a metal item to melt when it is placed in a rapidly changing magnetic field.

(iii) Speedometer: In an automobile's speedometer, a magnet is geared to the vehicle's main shaft and rotates in accordance with the vehicle's speed. Hair springs are used to secure the magnet in an aluminum cylinder. When the magnet rotates, it produces eddy currents in the drum and drags it through an angle, which indicates the speed of the vehicle on a calibrated scale.

(iv) Energy metre: The armature coil of an energy meter has a metallic aluminum disc that rotates between the poles of a pair of permanent horse shoe magnets. The current induced in the disc as the armature spins tends to oppose the motion

of the armature coil. Deflection is proportional to the energy consumed due to this braking effect.

5. Induced Charge Flow:

When a current is induced in the circuit due to the flux change, charge flows through the circuit and the net amount of charge which flows along the circuit

is given as : $q = \int i dt = \int \frac{1}{R} \left| \frac{d\phi}{dt} \right| dt = \frac{1}{R} \int d\phi$

$q = \frac{|\Delta\phi|}{R}$ and $q = N \frac{|\Delta\phi|}{R}$ for N turns.

6. Induced Electric Field:

It is non-conservative and non-electrostatic in nature. Its field lines are concentric circular closed curves.

A time varying magnetic field $\frac{dB}{dt}$ always produced induced electric field in all space surrounding it. Induced electric field (E_{in}) is directly proportional to induced

emf so $e = \oint \vec{E}_{in} \cdot d\vec{\ell}$... (i)

From Faraday's second laws $e = -\frac{d\phi}{dt}$... (ii)

From (i) and (ii) $e = \oint \vec{E}_{in} \cdot d\vec{\ell} = -\frac{d\phi}{dt}$. This is known as integral form of **Faraday's laws of EMI.**

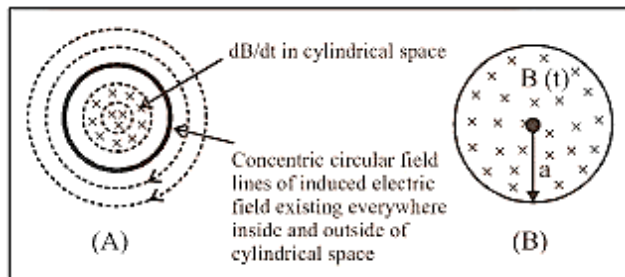



A uniform but time-varying magnetic field $B(t)$ exists in a circular region of radius ' a ' that is directed into the plane of the paper as shown, and the magnitude of the induced electric field (E_{in}) at point P , which is located at a distance r from the circular region's centre, is calculated as follows.

$$\oint \vec{E}_{in} \cdot d\vec{\ell} = e = \frac{d\phi}{dt} = A \frac{dB}{dt}$$

i.e. $E(2\pi r) = \pi a^2 \frac{dB}{dt}$

where $r \geq a$ or $E = \frac{a^2}{2r} \frac{dB}{dt}$; $E_{in} \propto \frac{1}{r}$

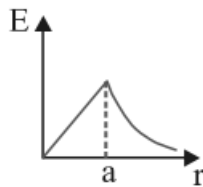

when $r < a$; $E = \frac{r}{2} \frac{dB}{dt}$; $E_n \propto r$.

7. Dynamic (Motional) Emi Due To Translatory Motion:

(i) Consider a conducting rod of length l moving with a uniform velocity \vec{v} perpendicular to a uniform magnetic field \vec{B} , directed into the plane of the paper. Let the rod be moving to the right as shown in figure. The conducting electrons also move to the right as they are trapped within the rod.

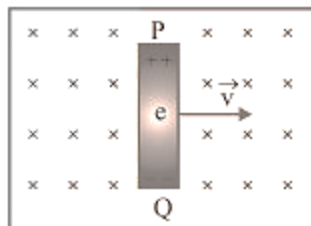

Conducting electrons experiences a magnetic force $F_m = evB$. So they move from P to Q within the rod. The end P of the rod becomes positively charged while end Q becomes negatively charged, hence an electric field is set up within the rod which opposes the further downward movement of electrons i.e. an equilibrium is reached and in equilibrium $F_c = F_m$ i.e. $eE = evB$ or $E = vB$

Induced emf $e = El = Bvl \left[E = \frac{V}{l} \right]$

(ii) If rod is moving by making an angle theta with the direction of magnetic field or length. Induced emf $e = Bvl \sin \theta$

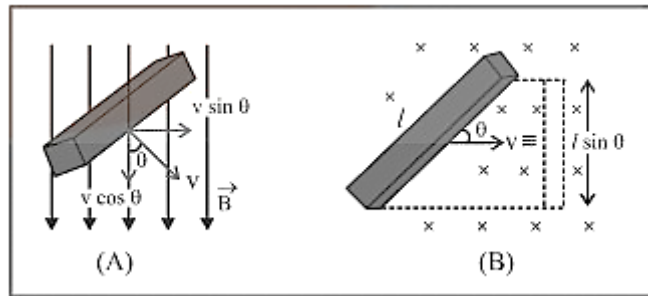

(iii) Motion of conducting rod on an inclined plane : When conductor start sliding from the top of an inclined plane as shown, it moves perpendicular to it's length but at an angle $(90 - \theta)$ with the direction of magnetic field.

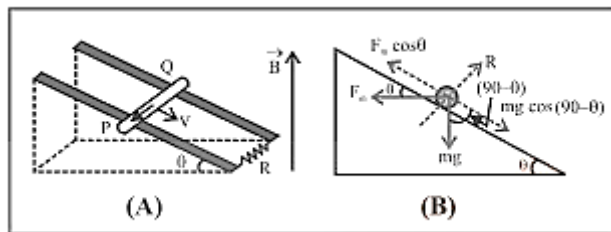

Hence induced emf across the ends of conductor $e = Bv \sin(90 - \theta)l = Bvl \cos \theta$

So, induced current, $i = \frac{Bvl \cos \theta}{R}$ (Directed from Q to P) .



The forces acting on the bar are shown in following figure. The rod will move down with constant velocity only if $F_m \cos \theta = mg \cos(90 - \theta) = mg \sin \theta$

$$\Rightarrow Bil \cos \theta = mg \sin \theta$$

$$\Rightarrow B \left(\frac{Bv_T \ell \cos \theta}{R} \right) \ell \cos \theta mg \sin \theta \Rightarrow v_T = \frac{mgR \sin \theta}{B^2 \ell^2 \cos^2 \theta}$$

8. Motional Emf In Loop By Generated Area:

If a conducting rod passes along two parallel conducting rails as illustrated in the diagram, the phenomena of induced emf may also be explained using the idea of generated area (the area swept by a conductor in a magnetic field while it moves).

As shown in figure in time t distance travelled by conductor = vt Area generated $A = lvt$. Flux linked with this area $\phi = BA = Blvt$

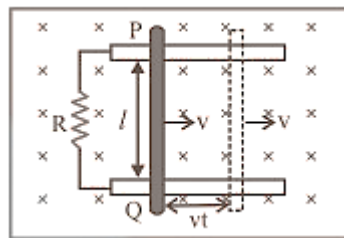

(i) Induced current :

$$i = \frac{e}{R} = \frac{Bv\ell}{R}$$

(ii) Magnetic force : Conductor PQ experiences a magnetic force in opposite direction of it's motion and

$$F_m = Bi\ell = B \left(\frac{Bv\ell}{R} \right) \ell = \frac{B^2 v \ell^2}{R}$$

(iii) Power dissipated in moving the conductor : For uniform motion of rod PQ , the rate of doing mechanical work by external agent or mech. Power delivered by external source is given as



$$P_{\text{mech}} = P_{\text{ext}} = \frac{dW}{dt} = F_{\text{ext}} \cdot v = \frac{B^2 v \ell^2}{R} \times v = \frac{B^2 v^2 \ell^2}{R}$$

(iv) Electrical power : Also electrical power dissipated in resistance or rate of heat dissipation across resistance is given as

$$P_{\text{thermal}} = \frac{H}{t} = i^2 R = \left(\frac{Bv\ell}{R} \right)^2 R; \quad P_{\text{thermal}} = \frac{B^2 v^2 \ell^2}{R}$$

(It is clear that $P_{\text{mech.}} = P_{\text{thermal}}$ which is consistent with the principle of conservation of energy.)

(v) Motion of conductor rod in a vertical plane : If conducting rod released from rest (at $t=0$) as shown in figure then with rise in it's speed (v), induces emf (e), induced current (i), magnetic force (F_m) increases but it's weight remains constant. Rod will achieve a constant maximum (terminal) velocity .

v_T if $F_m = mg$

$$\text{So, } \frac{B^2 v_T^2 \ell^2}{R} = mg \Rightarrow v_T = \frac{mgR}{B^2 \ell^2}$$

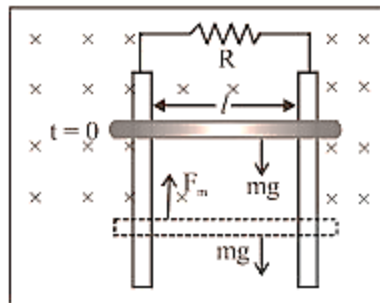

Special Cases:



(A)



(B)

Motion of train and aeroplane in earth's magnetic field

Induced emf across the axle of the wheels of the train and it is across the tips of the wing of the aeroplane is given by $e = B_v l v$ where l = length of the axle or distance between the tips of the wings of plane, B_v = vertical component of earth's magnetic field and v = speed of train or plane.

9. Motional Emi Due To Rotational Motion:

(i) Conducting rod: A conducting rod of length l whose one end is fixed, is rotated about the axis passing through it's fixed end and perpendicular to it's length with constant angular velocity ω . Magnetic field (B) is perpendicular to the plane of the paper. emf induces across the ends of the rod where ν = frequency (revolution per sec) and $T =$

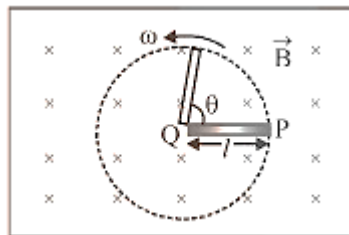

(ii) Cycle wheel: A conducting wheel each spoke of length l is rotating with angular velocity ω in a given magnetic field as shown below in fig. Due to flux cutting each metal spoke becomes identical cell of emf e (say), all such identical cells connected in parallel fashion $e_{net} = e$ (emf of single cell). Let N be the number of spokes hence $e_{net} = \frac{1}{2} B \omega l^2$; $\omega = 2\pi \nu$. Here $e_{net} \propto N^0$ i.e. total emf does not depends on number of spokes N .

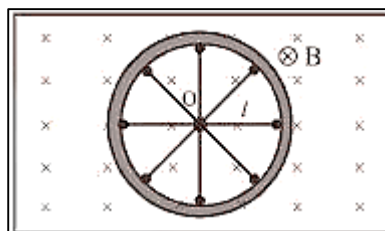

(iii) Faraday copper disc generator : A metal disc can be assumed to made of uncountable radial conductors when metal disc rotates in transverse magnetic

field these radial conductors cut away magnetic field lines and because of this flux cutting all becomes identical cells each of emf 'e' where $e = \frac{1}{2} B \omega r^2$

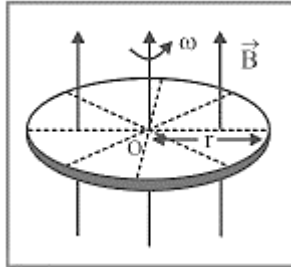

(iv) Semicircular conducting loop: If a semi-circular conducting loop (ACD) of radius 'r' with center at O, the plane of loop being in the plane of paper. The loop is now made to rotate with a constant angular velocity ω, about an axis passing through O and perpendicular to the plane of paper. The effective resistance of the loop is R.

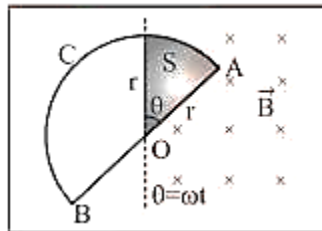

(v) In time t the area swept by the loop in the field i.e. region II

$$A = \frac{1}{2} r(r\theta) = \frac{1}{2} r^2 \omega t; \frac{dA}{dt} = \frac{r^2 \omega}{2}$$

Flux link with the rotating loop at time t, $\phi = BA$

Hence induced emf in the loop in magnitude $|e| = \frac{d\phi}{dt} = B \frac{dA}{dt} = \frac{B \omega r^2}{2}$ and induced

$$\text{current } i = \frac{|e|}{R} = \frac{B \omega r^2}{2R}$$

10. Periodic Emf: Suppose a rectangular coil having N turns placed initially in a magnetic field such that magnetic field is perpendicular to it's plane as shown-

ω – Angular speed

ν – Frequency of rotation of coil

R – Resistance of coil

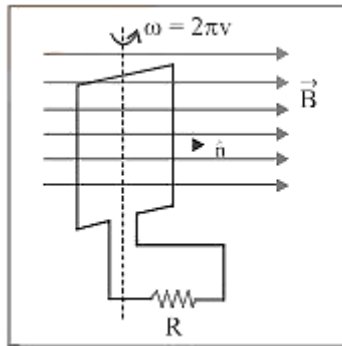

For uniform rotational motion with ω , the flux linked with coil at any time t ,

$$\phi = NBA \cos \theta = NBA \cos \omega t$$

$$\phi = \phi_0 \cos \omega t \text{ where } \phi_0 = NBA = \text{maximum flux}$$

(i) Induced emf in coil : Induced emf also changes in periodic manner that's why this phenomenon called periodic EMI

$$e = -\frac{d\phi}{dt} = NBA\omega \sin \omega t \Rightarrow e = e_0 \sin \omega t \text{ where } e_0 = \text{emf}$$

$$\text{amplitude or max. emf} = NBA\omega = \phi_0\omega$$

(ii) Induced current : At any time t , $i = \frac{e}{R} = \frac{e_0}{R} \sin \omega t = i_0 \sin \omega t$

where $i_0 =$ current amplitude or max. current

$$i_0 = \frac{e_0}{R} = \frac{NBA\omega}{R} = \frac{\phi_0\omega}{R}$$

11. Inductance:

(i) Inductance is an electrical circuit property that opposes any change in the circuit's current.

(ii) Inductance is a feature of electrical circuits that is intrinsic. Whether we desire it or not, it will always be found in an electrical circuit.

(iii) The inductance of a straight wire carrying electricity with no iron portion in the circuit will be lower.

(iv) Inductance in an electrical circuit is akin to inertia in mechanics, because inductance opposes any change in current in the circuit.

11.1. Self Induction:

Whenever the electric current passing through a coil or circuit changes, the magnetic flux linked with it will also change. As a result of this, in accordance with Faraday's laws of electromagnetic induction, an emf is induced in the coil or the circuit which opposes the change that causes it. This phenomenon is called 'self-induction' and the emf induced is called back emf, current so produced in the coil is called induced current.

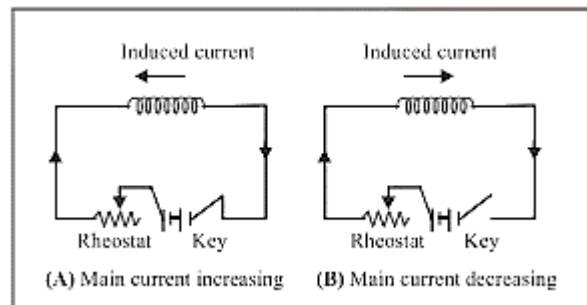

(i) Coefficient of self-induction : Number of flux linkages with the coil is proportional to the current i . i.e. $N\phi = Li$ (N is the number of turns in coil and $N\phi$ – total flux linkage). Hence $L = \frac{N\phi}{i}$ = coefficient of self-induction. .

(ii) If $i = 1\text{amp}$, $N = 1$ then, $L = \phi$ i.e. the coefficient of self induction of a coil is equal to the flux linked with the coil when the current in it is 1 amp.



(iii) By Faraday's second law induced emf. $e = -N \frac{d\phi}{dt}$ Which gives

$e = -L \frac{di}{dt}$; If $\frac{di}{dt} = \text{amp/sec}$ then $|e| = L$. Hence coefficient of self induction is equal to the emf induced in the coil when the rate of change of current in the coil is unity.

(iv) Units and dimensional formula of 'L' : It's S.I. unit

$$\frac{\text{weber}}{\text{Amp}} = \frac{\text{Tesla} \times \text{m}^2}{\text{Amp}} = \frac{\text{N} \times \text{m}}{\text{Amp}^2} = \frac{\text{Joule}}{\text{Amp}^2} = \frac{\text{Coulomb} \times \text{volt}}{\text{Amp}^2} = \frac{\text{volt} \times \text{sec}}{\text{amp}} = \text{ohm} \times \text{sec}$$

But practical unit is henry (**H**). It's dimensional formula $[L] = [ML^2T^{-2}A^{-2}]$

(v) Dependence of self inductance (L) : 'L' does not depend upon current flowing or change in current flowing but it depends upon number of turns (N), Area of cross section (A) and permeability of medium (μ). 'L' does not play any role till there is a constant current flowing in the circuit. 'L' comes in to the picture only when there is a change in current.

(vi) Magnetic potential energy of inductor : In building a steady current in the circuit, the source emf has to do work against of self inductance of coil and whatever energy consumed for this work stored in magnetic field of coil this energy called as magnetic potential energy (U) of coil.

$$U = \int_0^i L di = \frac{1}{2} Li^2$$

$$\text{Also, } U = \frac{1}{2} (Li)i = \frac{N\phi i}{2}$$

(vii) The various formulae for L

Condition	Figure
Circular Coil $L = \frac{\mu_0 \pi N^2 r}{2}$	

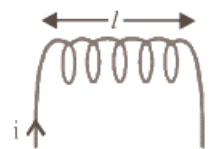
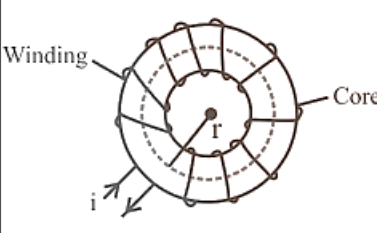
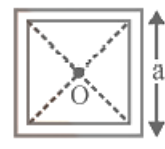
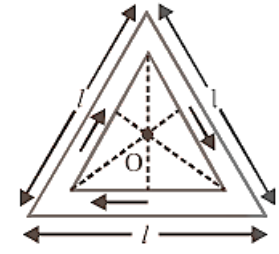
<p>Solenoid</p> $L = \frac{\mu_0 N^2 r}{\ell} = \mu_0 n^2 A \ell$	
<p>Toroid</p>	
<p>Square Coil</p> $L = \frac{2\sqrt{2}\mu_0 N^2 a}{\pi}$	
<p>Triangular Coil</p> $B = \frac{\mu_0 \cdot 18Ni}{4\pi \ell}$ $L = \frac{N \left(\frac{\mu_0 \cdot 18Ni}{4\pi \ell} \right) \times \left(\frac{\sqrt{3}}{4} \ell^2 \right)}{i}$	

11.1. Mutual Induction:

Whenever the current passing through a coil or circuit changes, the magnetic flux linked with a neighbouring coil or circuit will also change. Hence an emf will be induced in the neighboring coil or circuit. This phenomenon is called ‘**mutual**

induction'.

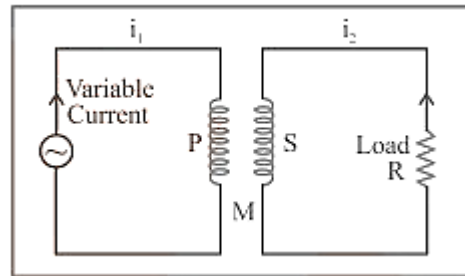

(i) Coefficient of mutual induction : Total flux linked with the secondary due to current in the primary is $N_2\phi_2$ and $N_2\phi_2 \propto i_1 \Rightarrow N_2\phi_2 = Mi_1$ where N_1 - Number of turns in primary; N_2 - Number of turns in secondary; ϕ_2 - Flux linked with each turn of secondary; i_1 - Current flowing through primary; M - Coefficient of mutual induction or mutual inductance.

(ii) According to Faraday's second law emf induces in secondary $e_2 = -N_2 \frac{d\phi_2}{dt}$; $e_2 = -M \frac{di_1}{dt}$

(iii) If $\frac{di_1}{dt} = \frac{1\text{Amp}}{\text{sec}}$ then $|e_2| = M$. Hence coefficient of mutual induction is equal to the emf induced in the secondary coil when rate of change of current in primary coil is unity .

(iv) Units and dimensional formula of M : Similar to self-inductance (**L**)

(v) Dependence of mutual inductance:

(vi) Number of turns (N_1 , N_2) of both coils

(vii) Coefficient of self inductances (L_1 , L_2) of both the coils

(viii) Area of cross-section of coils

(ix) Magnetic permeability of medium between the coils (μ_r) or nature of material on which two coils are wound

(x) Distance between two coils (As d increases so M decreases) (vi) Orientation between primary and secondary coil (for 90° orientation no flux relation $M = 0$)

(xi) Coupling factor ‘ K ’ between primary and secondary coil.

(xii) Relation between M , L_1 and L_2 : For two magnetically coupled coils

$M = K\sqrt{L_1L_2}$ where k – coefficient of coupling or coupling factor which is defined as; $K = \frac{\text{Magnetic flux linked in secondary}}{\text{Magnetic flux linked in primary}}$

$$0 \leq K \leq 1$$

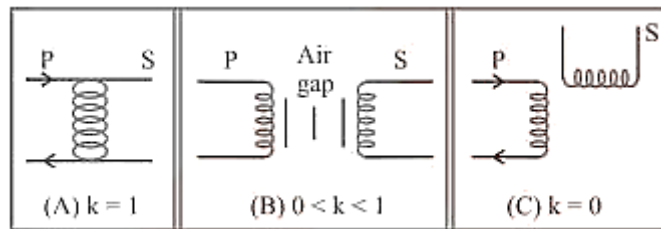

(xiii) The various formulae for M :

Condition	Figure
Two concentric coplaner circular coils $M = \frac{\pi\mu_0 N_1 N_2 r^2}{2R}$	
Two Solenoids $M = \frac{\mu_0 N_1 N_2 A}{\ell}$	



<p>Two concentric coplaner square coils</p> $M = \frac{\mu_0 2\sqrt{2} N_1 N_2 \ell^2}{\pi L}$	
--	--

12. Combination of Inductance

(i) Series : If two coils of self-inductances L_1 and L_2 having mutual inductance are in series and are far from each other, so that the mutual induction between them is negligible, then net self inductance

$$L_s = L_1 + L_2$$

When they are situated close to each other, then net inductance

$$L_s = L_1 + L_2 \pm 2M$$

(ii) Parallel : If two coils of self-inductances L_1 and L_2 having mutual inductance are connected in parallel and are far from each other, then net inductance L is



$$\frac{1}{L_p} = \frac{1}{L_1} + \frac{1}{L_2} \Rightarrow L_p = \frac{L_1 L_2}{L_1 + L_2}$$

When they are situated close to each other, then

$$L_p = \frac{L_1 L_2 - M^2}{L_1 + L_2 \pm 2M}$$

<p>Mutual induction is absent(k=0)</p>	<p>Mutual induction is present and favors self-induction of coils</p>	<p>Mutual induction is present and opposes self-induction of coils</p>
---	--	---

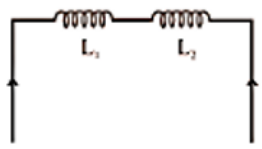
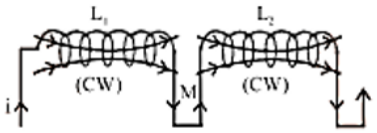
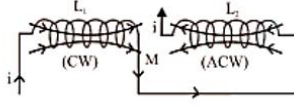
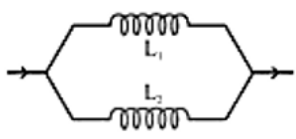

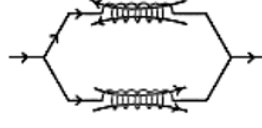
 $L_{eq} = L_1 + L_2$	 <p>Current in same direction Winding nature same Their flux assist each other</p> $L_m = L_1 + L_2 + 2M$	 <p>Current in opposite direction Opposite winding nature Their flux opposes each other</p> $L_{eq} = L_1 + L_2 - 2M$
 $L_{eq} = \frac{L_1 L_2}{L_1 + L_2}$	 $L_{eq} = \frac{L_1 L_2 - M^2}{L_1 + L_2 + 2M}$	 $L_{eq} = \frac{L_1 L_2 - M^2}{L_1 + L_2 - 2M}$

13. Growth And Decay of Current In Lr Circuit:

When a circuit with a pure inductor L and a resistor R in series with a battery and a key is closed, the current through the circuit climbs exponentially until it reaches a maximum value (steady state). When a circuit is opened from its steady state, the current flowing through it diminishes exponentially.

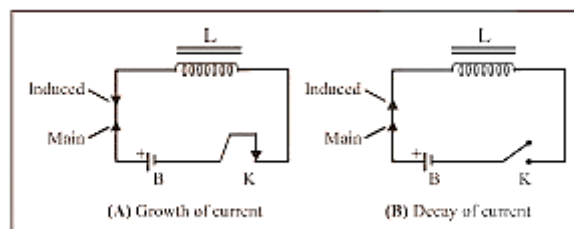

(i) The value of current at any instant of time t after closing the circuit (i.e. during the rising of current) is given by $i = i_0 \left[1 - e^{-\frac{R}{L}t} \right]$; where $i_0 = i_{\max} = \frac{E}{R}$ = steady state current.

(ii) The value of current at any instant of time t after opening from the steady state condition (i.e. during the decaying of current) is given by $i = i_0 e^{-\frac{R}{L}t}$

(iii) Time constant (τ) : It is given as $\tau = \frac{L}{R}$; It's unit is second. In other words the time interval, during which the current in an inductive circuit rises to 63% of its maximum value at make, is defined as time constant or it is the time interval, during which the current after opening an inductive circuit falls to 37% of its maximum value.

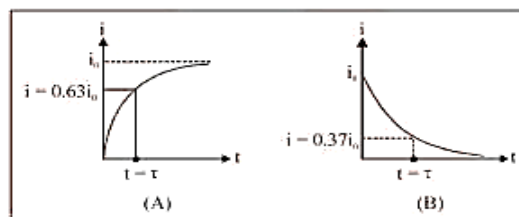

(iv) Behaviour of inductor: The current in the circuit grows exponentially with time from 0 to the maximum value $i \left(= \frac{E}{R} \right)$. Just after closing the switch as $i = 0$, inductor act as open circuit i.e. broken wires and long after the switch has been closed as $i = i_0$, the inductor act as a short circuit i.e. a simple connecting wire.

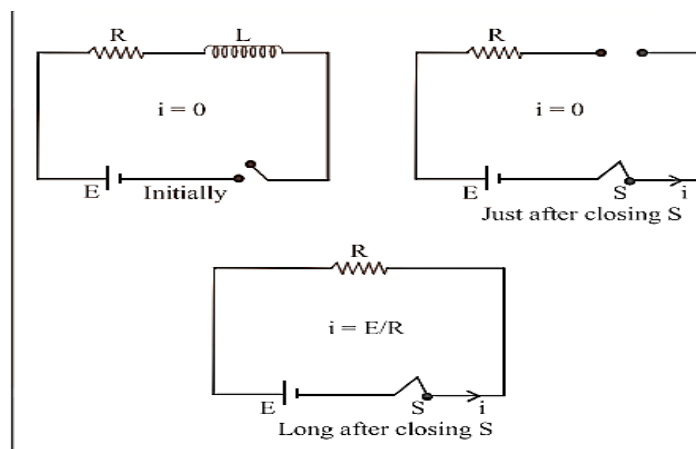

13. Lc Oscillation:

When a charged capacitor C having an initial charge q_0 is discharged through an inductance L , the charge and current in the circuit start oscillating simple harmonically. If the resistance of the circuit is zero, no energy is dissipated as heat. We also assume an idealized situation in which energy is not radiated away from the circuit. The total energy associated with the circuit is constant.

Frequency of oscillation is given by: $\omega = \frac{1}{\sqrt{LC}} \text{ rad/sec}$

Or $= \frac{1}{2\pi\sqrt{LC}} \text{ Hz}$

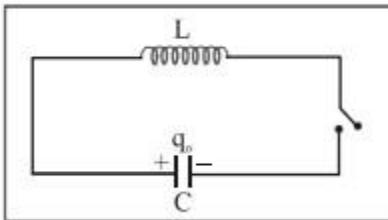

The oscillation of the LC circuit are an electromagnetic analog to the mechanical oscillation of a block-spring system.

<p>At $t = 0$, capacitor is ready to discharge.</p>	<p>At $t = 0$ block is ready to move.</p>
--	--

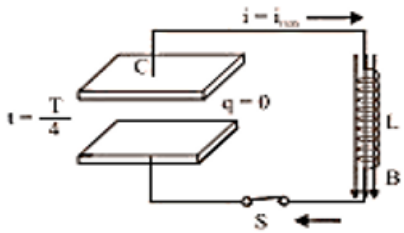
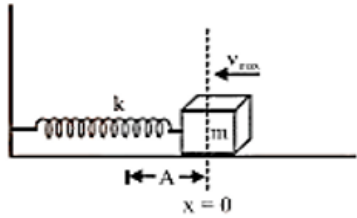
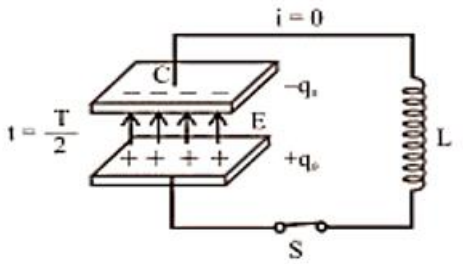
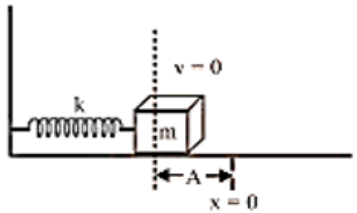
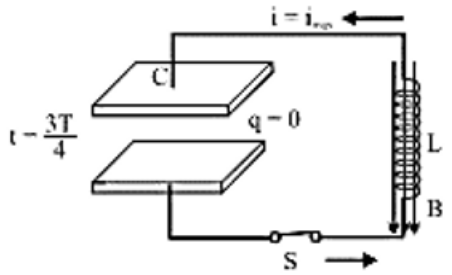
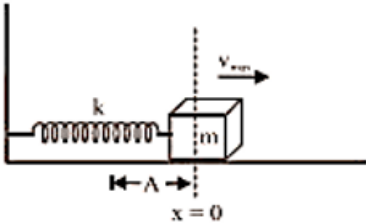
 <p>At $t = \frac{T}{4}$, capacitor is fully, discharged i.e charge $q=0$ and current is maximum</p>	 <p>At $t = \frac{T}{4}$, block comes in it's mean position i.e. $x=0$ and velocity of block becomes maximum</p>
 <p>At $t = \frac{T}{2}$, capacitor is again recharged with reverse polarity and $i=0$</p>	 <p>At $t = \frac{T}{2}$, block reaches it's extreme position other side and $v=0$</p>
 <p>At $t = \frac{3T}{4}$, block again</p>	 <p>At $t = \frac{3T}{4}$, block again</p>

<p>At $t = \frac{3T}{4}$, capacitor again discharged completely $i=i_{\max}$</p>	<p>reaches it's mean position and it's velocity becomes maximum.</p>

14. Dc Motor:

It's a machine that turns electrical energy into mechanical energy.

(i) Principle : It is based on the fact that a current carrying capacity of a current carrying capacity of a current carrying capacity of a current carrying capacity

When a coil is placed in a magnetic field, it produces a torque.

This The coil is rotated by torque.

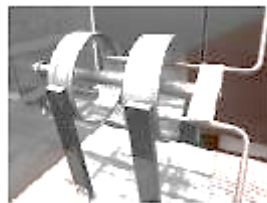

(ii) Construction: It is made up of the components shown in the diagram.

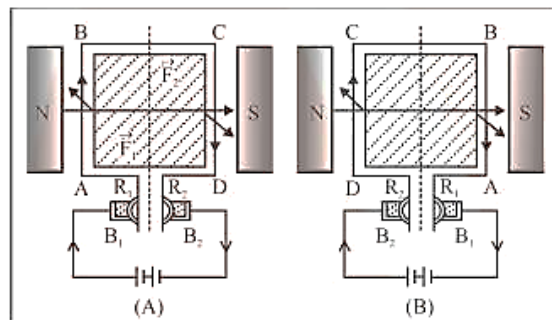

ABCD = Armature coil, S_1, S_2 = split ring comutators
 B_1, B_2 = Carbon brushes, N, S = Strong magnetic poles

(iii) Working : Force on any arm of the coil is given by $\vec{F} = i(\vec{l} \times \vec{B})$

The force applied on AB will be perpendicular to the paper's plane and pointing inwards. On the CD , the force will be equal and opposite. When viewed from the top, the coil turns in a clockwise direction. Due to commutation, the current in AB reverses, but the force on AB and CD remains in the same direction, causing the coil to rotate in the same direction.

(iv) Back emf in motor : Due to the rotation of armature coil in magnetic field a back emf is induced in the circuit. Which is given by $e = E - iR$. Back emf directly depends upon the angular velocity of armature and magnetic field B . But for constant magnetic field B , value of back emf e is given by $e \propto \omega$ or $e = k\omega$ ($e = NBA \sin t$)

(v) Current in the motor: $i = \frac{E - e}{R} = \frac{E - k\omega}{R}$ When motor is just switched on i.e. $\omega = 0$

so $e = 0$ hence $i = \frac{E}{R}$ = maximum and at full speed, i is minimum so back emf e is maximum and i is minimum. Thus, maximum current is drawn when the motor is just switched on which decreases when motor attains the speed.

(vi) Motor starter: When the motor is started, a tremendous current passes through it, potentially burning it out. As a result, a starter is used to securely start a dc motor. Its purpose is to put an appropriate resistance into the circuit when the motor is turned on. When the motor is running at maximum speed, the resistance steadily lowers until it reaches zero.

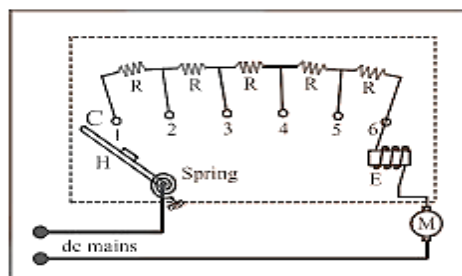

The value of starting resistance is maximum at time $t = 0$ and its value is controlled by spring and electromagnetic system and is made to zero when the motor attains its safe speed.

(vi) Mechanical power and Efficiency of dc motor:

$$\text{Efficiency } \eta = \frac{P_{\text{mechanical}}}{P_{\text{supplied}}} = \frac{P_{\text{out}}}{P_{\text{in}}} = \frac{e}{E} = \frac{\text{Back e.m.f.}}{\text{Supply voltage}}$$

(vii) Uses of *dc* motors : They are used in electric locomotives, electric fans, rolling mills, electric cranes, electric lifts, dc drills, fans and blowers, centrifugal pumps and air compressors, etc.

15. Dc Generator:

If the current produced by the generator is direct current, then the generator is called dc generator. dc generator consists of

- (i) Armature (coil)
- (ii) Magnet
- (iii) Commutator
- (iv) Brushes

In dc generator commutator is used in place of slip rings. The commutator rotates along with the coil so that in every cycle when direction of 'e' reverses, the commutator also reverses or makes contact with the other brush so that in the external load the current remains in the same direction giving dc.

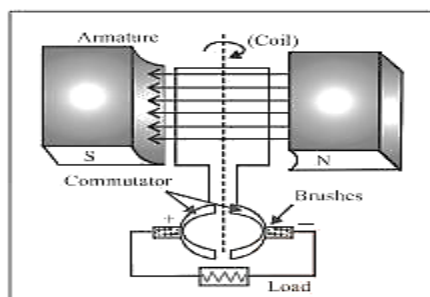

Tips And Tricks:

- (i) If a bar magnet moves towards a fixed conducting coil, then due to the flux changes an emf, current and charge induces in the coil. If speed of magnet increases then induced emf and induced current increases but induced charge



remains same Induced parameter : e_1, i_1, q_1

$$e_2 (> e_1), i_2 (> i_1), q_2 (= q_1)$$

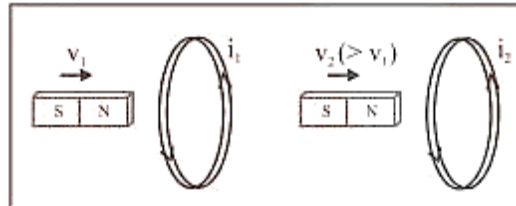

(ii) Can ever electric lines of force be closed curve ? Yes, when produced by a changing magnetic field.

(iii) No flux cutting \longrightarrow No EMI

(iv) Vector form of motional emf : $e = (\vec{v} \times \vec{B}) \cdot \vec{l}$

(v) In motional emf \vec{v}, \vec{B} and \vec{l} are three vectors. If any two vector are parallel – No flux cutting.

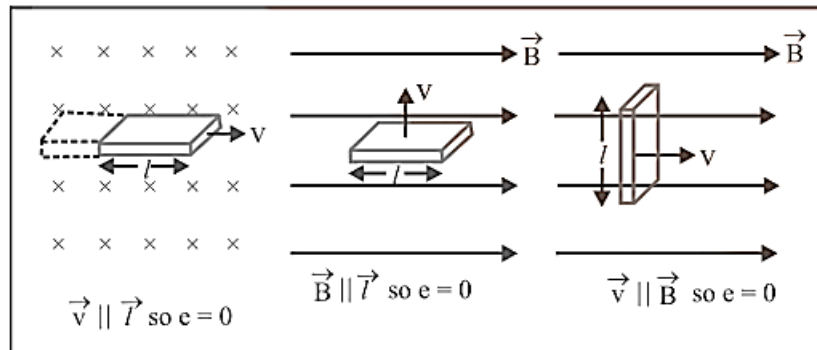

(vi) A piece of metal and a piece of non-metal are dropped from the same height near the surface of the earth. The non metallic piece will reach the ground first because there will be no induced current in it.

(vii) If an aeroplane is landing down or taking off and its wings are in the east-west direction, then the potential difference or emf will be induced across the wings. If an aeroplane is landing down or taking off and its wings are in the northsouth direction, then no potential difference or emf will be induced.

(viii) When a conducting rod moving horizontally on equator of earth no emf



induces because there is no vertical component of earth's magnetic field. But at poles B_V is maximum so maximum flux cutting hence emf induces.

(ix) When a conducting rod falling freely in earth's magnetic field such that its length lies along East - West direction then induced emf continuously increases w.r.t. time and induced current flows from West - East.

(x) $1 \text{ henry} = 10^9 \text{ emu}$ of inductance or 10^9 ab-henry .

(xi) Inductance at the ends of a solenoid is half of its the inductance at the centre

$$\left(L_{\text{end}} = \frac{1}{2} L_{\text{centre}} \right)$$

(xii) A thin, long wire composed of a high-resistivity material acts primarily as a resistance. It does, however, contain some inductance and capacitance. As a result, obtaining a pure resistor is challenging. Pure capacitors and inductors are similarly difficult to come by.

(xiii) A resistive circuit with no capacitive or inductive elements contains some inductance because of the intrinsic presence of self inductance in all electrical circuits.

Self-inductance can be reduced by doubling back the coil on itself, as in the coils of a resistance box.

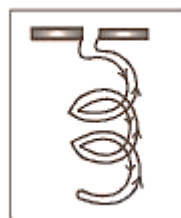

(xiv) It is not possible to have mutual inductance without self inductance but it may or may not be possible self inductance without mutual inductance.

(xv) If main current through a coil increases ($i \uparrow$) so $\frac{di}{dt}$ will be positive (+ve), hence induced emf e will be negative (i.e. opposite emf) $= E_{\text{net}} = E - e$

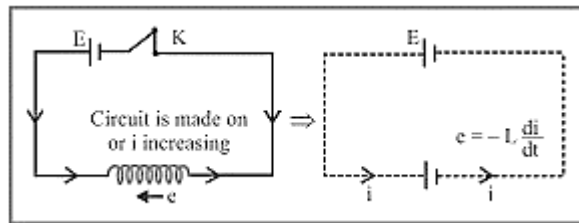

(xvi) Due to the high inductance of the circuit, a high temporarily induced emf is sometimes produced when the key is suddenly opened, resulting in sparking at the key position. A capacitor is put across the key to prevent sparking.

(xvii) Due to the high inductance of the circuit, a high temporarily induced emf is sometimes produced when the key is suddenly opened, resulting in sparking at the key position. A capacitor is put across the key to prevent sparking.

(xviii) Resistance can exist with or without inductance, but inductance cannot exist without resistance.

(xix) An inductor's circuit behavior differs significantly from that of a resistor. while a resistor opposes the current i , an inductor opposes the change $\frac{di}{dt}$ in the circuit.

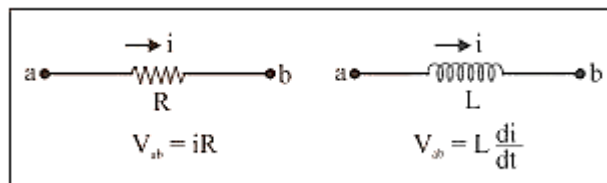

(xx) In RL-circuit with dc source the time taken by the current to reach half of the maximum value is called half life time and it is given by

$$T = 0.693 \frac{L}{R}$$

(xxi) The dc motor is a versatile energy conversion device that can be used in a variety of applications. It can handle loads that require a lot of starting torque, as well as accelerating and decelerating torque.



(xxii) Ohm's law can be utilised when a source of emf is linked across the two ends of the primary winding or the two ends of the secondary winding alone. However, because the primary and secondary windings are not electrically coupled, ohm's law should not be applied to the transformer as a whole.

(xxiii) Even when the transformer's secondary circuit is open, it pulls a current termed no load primary current to supply no load Cu and iron losses.

(xxiv) Transformer has highest possible efficiency out of all the electrical machines.