



FINAL JEE–MAIN EXAMINATION – JANUARY, 2023
Held On Wednesday 25th January, 2023
TIME : 03:00 PM to 06:00 PM

SECTION-A

61. Let the function $f(x)=2x^3 + (2p-7)x^2+3(2p-9)x-6$ have a maxima for some value of $x < 0$ and a minima for some value of $x > 0$. Then, the set of all values of p is

- (1) $\left(\frac{9}{2}, \infty\right)$ (2) $\left(0, \frac{9}{2}\right)$
 (3) $\left(-\infty, \frac{9}{2}\right)$ (4) $\left(-\frac{9}{2}, \frac{9}{2}\right)$

Official Ans. by NTA (3)

Ans. (3)

Sol. $f(x) = 2x^3 + (2p - 7)x^2 + 3(2p - 9)x - 6$

$$f'(x) = 6x^2 + 2(2p - 7)x + 3(2p - 9)$$

$$f'(0) < 0$$

$$\therefore 3(2p - 9) < 0$$

$$p < \frac{9}{2}$$

$$p \in \left(-\infty, \frac{9}{2}\right)$$

62. Let z be a complex number such that

$$\left| \frac{z - 2i}{z + i} \right| = 2, z \neq -i. \text{ Then } z \text{ lies on the circle of}$$

radius 2 and centre

- (1) (2, 0) (2) (0, 0)
 (3) (0, 2) (4) (0, -2)

Official Ans. by NTA (4)

Ans. (4)

Sol. $(z - 2i)(\bar{z} + 2i) = 4(z + i)(\bar{z} - i)$

$$z\bar{z} + 4 + 2i(z - \bar{z}) = 4(z\bar{z} + 1 + i(\bar{z} - z))$$

$$3z\bar{z} - 6i(z - \bar{z}) = 0$$

$$x^2 + y^2 - 2i(2iy) = 0$$

$$x^2 + y^2 + 4y = 0$$

63. If the function

$$f(x) = \begin{cases} (1 + |\cos x|) \frac{\lambda}{|\cos x|}, & 0 < x < \frac{\pi}{2} \\ \mu, & x = \frac{\pi}{2} \\ e^{\frac{\cot 6x}{\cot 4x}}, & \frac{\pi}{2} < x < \pi \end{cases} \text{ is continuous at}$$

$x = \frac{\pi}{2}$, then $9\lambda + 6\log_e \mu + \mu^6 - e^{6\lambda}$ is equal to

- (1) 11 (2) 8
 (3) $2e^4 + 8$ (4) 10

Official Ans. by NTA (DROP)

Sol. $\Rightarrow \lim_{x \rightarrow \frac{\pi}{2}^-} e^{\frac{\cot 6x}{\cot 4x}} = \lim_{x \rightarrow \frac{\pi}{2}^-} e^{\frac{\sin 4x \cdot \cos 6x}{\sin 6x \cdot \cos 4x}} = e^{2/3}$

$$\Rightarrow \lim_{x \rightarrow \frac{\pi}{2}^-} (1 + |\cos x|)^{\frac{\lambda}{|\cos x|}} = e^\lambda$$

$$\Rightarrow f(\pi/2) = \mu$$

For continuous function $\Rightarrow e^{2/3} = e^\lambda = \mu$

$$\lambda = \frac{2}{3}, \mu = e^{2/3}$$

Now, $9\lambda + 6\log_e \mu + \mu^6 - e^{6\lambda} = 10$

64. Let $f(x) = 2x^n + \lambda, \lambda \in \mathbb{R}, n \in \mathbb{N}$, and $f(4)=133,$

$f(5)=255$. Then the sum of all the positive integer divisors of $(f(3)-f(2))$ is

- (1) 61 (2) 60
 (3) 58 (4) 59

Official Ans. by NTA (2)

Ans. (2)

Sol. $f(x) = 2x^n + \lambda$

$$f(4) = 133$$

$$f(5) = 255$$

$$133 = 2 \times 4^n + \lambda \quad (1)$$

$$255 = 2 \times 5^n + \lambda \quad (2)$$



(2) - (1)

$122 = 2(5^n - 4^n)$

$\Rightarrow 5^n - 4^n = 61$

$\therefore n = 3 \text{ \& } \lambda = 5$

Now, $f(3) - f(2) = 2(3^3 - 2^3) = 38$

Number of Divisors is 1, 2, 19, 38 ; & their sum is 60

65. If the four points, whose position vectors are $3\hat{i} - 4\hat{j} + 2\hat{k}, \hat{i} + 2\hat{j} - \hat{k}, -2\hat{i} - \hat{j} + 3\hat{k}$ and $5\hat{i} - 2\alpha\hat{j} + 4\hat{k}$ are coplanar, then α is equal to

(1) $\frac{73}{17}$

(2) $-\frac{107}{17}$

(3) $-\frac{73}{17}$

(4) $\frac{107}{17}$

Official Ans. by NTA (1)

Ans. (1)

Sol. Let A : (3, -4, 2) C : (-2, -1, 3)

B : (1, 2, -1) D : (5, -2 α , 4)

A, B, C, D are coplanar points, then

$$\Rightarrow \begin{vmatrix} 1-3 & 2+4 & -1-2 \\ -2-3 & -1+4 & 3-2 \\ 5-3 & -2\alpha+4 & 4-2 \end{vmatrix} = 0$$

$\Rightarrow \alpha = \frac{73}{17}$

66. Let $A = \begin{bmatrix} 1 & 3 \\ \sqrt{10} & \sqrt{10} \\ -3 & 1 \\ \sqrt{10} & \sqrt{10} \end{bmatrix}$ and $B = \begin{bmatrix} 1 & -i \\ 0 & 1 \end{bmatrix}$, where

$i = \sqrt{-1}$. If $M = A^T B A$, then the inverse of the matrix $A M^{2023} A^T$ is

(1) $\begin{bmatrix} 1 & -2023i \\ 0 & 1 \end{bmatrix}$

(2) $\begin{bmatrix} 1 & 0 \\ -2023i & 1 \end{bmatrix}$

(3) $\begin{bmatrix} 1 & 0 \\ 2023i & 1 \end{bmatrix}$

(4) $\begin{bmatrix} 1 & 2023i \\ 0 & 1 \end{bmatrix}$

Official Ans. by NTA (4)

Ans. (4)

Sol. $AA^T = \begin{bmatrix} 1 & 3 \\ \sqrt{10} & \sqrt{10} \\ -3 & 1 \\ \sqrt{10} & \sqrt{10} \end{bmatrix} \begin{bmatrix} 1 & -3 \\ \sqrt{10} & \sqrt{10} \end{bmatrix} = \begin{bmatrix} 1 & 0 \\ 0 & 1 \end{bmatrix}$

$B^2 = \begin{bmatrix} 1 & -i \\ 0 & 1 \end{bmatrix} \begin{bmatrix} 1 & -i \\ 0 & 1 \end{bmatrix} = \begin{bmatrix} 1 & -2i \\ 0 & 1 \end{bmatrix}$

$B^3 = \begin{bmatrix} 1 & -3i \\ 0 & 1 \end{bmatrix}$

$B^{2023} = \begin{bmatrix} 1 & -2023i \\ 0 & 1 \end{bmatrix}$

$M = A^T B A$

$M^2 = M.M = A^T B A A^T B A = A^T B^2 A$

$M^3 = M^2.M = A^T B^2 A A^T B A = A^T B^3 A$

$M^{2023} = \dots\dots\dots A^T B^{2023} A$

$A M^{2023} A^T = \underline{A A^T} B^{2023} \underline{A A^T} = B^{2023}$

$= \begin{bmatrix} 1 & -2023i \\ 0 & 1 \end{bmatrix}$

Inverse of $(A M^{2023} A^T)$ is $\begin{bmatrix} 1 & 2023i \\ 0 & 1 \end{bmatrix}$

67. Let $\Delta, \nabla \in \{\wedge, \vee\}$ be such that $(p \rightarrow q) \Delta (p \nabla q)$

is a tautology. Then

(1) $\Delta = \wedge, \nabla = \vee$ (2) $\Delta = \vee, \nabla = \wedge$

(3) $\Delta = \vee, \nabla = \vee$ (4) $\Delta = \wedge, \nabla = \wedge$

Official Ans. by NTA (3)

Ans. (3)

Sol. Given $(p \rightarrow q) \Delta (p \nabla q)$

Option 1 $\Delta = \wedge, \nabla = \vee$

p	q	$(p \rightarrow q)$	$(p \vee q)$	$(p \rightarrow q) \wedge (p \vee q)$
T	T	T	T	T
T	F	F	T	F
F	T	T	T	T
F	F	T	F	F

Option 2 $\Delta = \vee, \nabla = \wedge$

p	q	$(p \rightarrow q)$	$(p \wedge q)$	$(p \rightarrow q) \vee (p \wedge q)$
T	T	T	T	T
T	F	F	F	F
F	T	T	F	T
F	F	T	F	T

Option 3 $\Delta = \vee, \nabla = \vee$

p	q	$(p \rightarrow q)$	$(p \vee q)$	$(p \rightarrow q) \vee (p \wedge q)$
T	T	T	T	T
T	F	F	T	T
F	T	T	T	T
F	F	T	F	T

Hence, it is tautology.

Option 4 $\Delta = \wedge, \nabla = \wedge$

p	q	$(p \rightarrow q)$	$(p \wedge q)$	$(p \rightarrow q) \wedge (p \wedge q)$
T	T	T	T	T
T	F	F	F	F
F	T	T	F	F
F	F	T	F	F

68. The number of numbers, strictly between 5000 and 10000 can be formed using the digits 1,3,5,7,9 without repetition, is

- (1) 6 (2) 12
(3) 120 (4) 72

Official Ans. by NTA (4)

Ans. (4)

Sol. Numbers between 5000 & 10000

Using digits 1, 3, 5, 7, 9

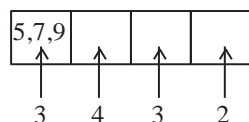

Total Numbers = $3 \times 4 \times 3 \times 2 = 72$

69. The number of functions $f : \{1, 2, 3, 4\} \rightarrow \{a \in \mathbb{Z} : |a| \leq 8\}$ satisfying $f(n) +$

$\frac{1}{n} f(n+1) = 1, \forall n \in \{1, 2, 3\}$ is

- (1) 3 (2) 4
(3) 1 (4) 2

Official Ans. by NTA (4)

Ans. (4)

Sol. $f : \{1, 2, 3, 4\} \rightarrow \{a \in \mathbb{Z} : |a| \leq 8\}$

$f(n) + \frac{1}{n} f(n+1) = 1, \forall n \in \{1, 2, 3\}$

$f(n+1)$ must be divisible by n

$f(4) \Rightarrow -6, -3, 0, 3, 6$

$f(3) \Rightarrow -8, -6, -4, -2, 0, 2, 4, 6, 8$

$f(2) \Rightarrow -8, \dots, 8$

$f(1) \Rightarrow -8, \dots, 8$

$\frac{f(4)}{3}$ must be odd since $f(3)$ should be even

therefore 2 solution possible.

$f(4)$	$f(3)$	$f(2)$	$f(1)$
-3	2	0	1
3	0	1	0

70. The equations of two sides of a variable triangle are $x = 0$ and $y = 3$, and its third side is a tangent to the parabola $y^2 = 6x$. The locus of its circumcentre is :

- (1) $4y^2 - 18y - 3x - 18 = 0$ (2) $4y^2 + 18y + 3x + 18 = 0$
(3) $4y^2 - 18y + 3x + 18 = 0$ (4) $4y^2 - 18y - 3x + 18 = 0$

Official Ans. by NTA (3)

Ans. (3)

Sol. $y^2 = 6x$ & $y^2 = 4ax$

$\Rightarrow 4a = 6 \Rightarrow a = \frac{3}{2}$

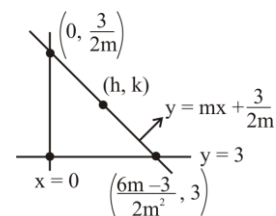



$$y = mx + \frac{3}{2m}; (m \neq 0)$$

$$h = \frac{6m-3}{4m^2}, k = \frac{6m+3}{4m}, \text{ Now eliminating } m \text{ and}$$

we get

$$\Rightarrow 3h = 2(-2k^2 + 9k - 9)$$

$$\Rightarrow 4y^2 - 18y + 3x + 18 = 0$$

71. Let $f: \mathbb{R} \rightarrow \mathbb{R}$ be a function defined by $f(x) = \log_{\sqrt{m}} \left\{ \sqrt{2}(\sin x - \cos x) + m - 2 \right\}$, for some m , such that the range of f is $[0, 2]$. Then the value of m is _____

- (1) 5 (2) 3 (3) 2 (4) 4

Official Ans. by NTA (1)

Ans. (1)

Sol. Since,

$$-\sqrt{2} \leq \sin x - \cos x \leq \sqrt{2}$$

$$\therefore -2 \leq \sqrt{2}(\sin x - \cos x) \leq 2$$

$$(\text{Assume } \sqrt{2}(\sin x - \cos x) = k)$$

$$-2 \leq k \leq 2 \quad \dots(i)$$

$$f(x) = \log_{\sqrt{m}}(k + m - 2)$$

Given,

$$0 \leq f(x) \leq 2$$

$$0 \leq \log_{\sqrt{m}}(k + m - 2) \leq 2$$

$$1 \leq k + m - 2 \leq m$$

$$-m + 3 \leq k \leq 2 \quad \dots(ii)$$

From eq. (i) & (ii), we get $-m + 3 = -2$

$$\Rightarrow m = 5$$

72. Let A, B, C be 3×3 matrices such that A is symmetric and B and C are skew-symmetric.

Consider the statements

(S1) $A^{13}B^{26} - B^{26}A^{13}$ is symmetric

(S2) $A^{26}C^{13} - C^{13}A^{26}$ is symmetric

Then,

- (1) Only S2 is true
 (2) Only S1 is true
 (3) Both S1 and S2 are false
 (4) Both S1 and S2 are true

Official Ans. by NTA (1)

Ans. (1)

Sol. Given, $A^T = A, B^T = -B, C^T = -C$

$$\text{Let } M = A^{13}B^{26} - B^{26}A^{13}$$

$$\text{Then, } M^T = (A^{13}B^{26} - B^{26}A^{13})^T$$

$$= (A^{13}B^{26})^T - (B^{26}A^{13})^T$$

$$= (B^T)^{26}(A^T)^{13} - (A^T)^{13}(B^T)^{26}$$

$$= B^{26}A^{13} - A^{13}B^{26} = -M$$

Hence, M is skew symmetric

$$\text{Let, } N = A^{26}C^{13} - C^{13}A^{26}$$

$$\text{then, } N^T = (A^{26}C^{13})^T - (C^{13}A^{26})^T$$

$$= -(C^{13})^T(A^{26})^T + A^{26}C^{13} = N$$

Hence, N is symmetric.

\therefore Only S2 is true.

73. Let $y=y(t)$ be a solution of the differential equation

$$\frac{dy}{dt} + \alpha y = \gamma e^{-\beta t}$$

Where, $\alpha > 0, \beta > 0$ and $\gamma > 0$. Then $\lim_{t \rightarrow \infty} y(t)$

- (1) is 0 (2) does not exist
 (3) is 1 (4) is -1

Official Ans. by NTA (1)

Ans. (1)

Sol. $\frac{dy}{dt} + \alpha y = \gamma e^{-\beta t}$

$$\text{I.F.} = e^{\int \alpha dt} = e^{\alpha t}$$

$$\text{Solution} \Rightarrow y \cdot e^{\alpha t} = \int \gamma e^{-\beta t} \cdot e^{\alpha t} dt$$

$$\Rightarrow ye^{\alpha t} = \gamma \frac{e^{(\alpha-\beta)t}}{(\alpha-\beta)} + c$$

$$\Rightarrow y = \frac{\gamma}{e^{\beta t}(\alpha-\beta)} + \frac{c}{e^{\alpha t}}$$

$$\text{So, } \lim_{t \rightarrow \infty} y(t) = \frac{\gamma}{\infty} + \frac{c}{\infty} = 0$$

74. $\sum_{k=0}^6 {}^{51-k}C_3$ is equal to

- (1) ${}^{51}C_4 - {}^{45}C_4$ (2) ${}^{51}C_3 - {}^{45}C_3$
 (3) ${}^{52}C_4 - {}^{45}C_4$ (4) ${}^{52}C_3 - {}^{45}C_3$

Official Ans. by NTA (3)

Ans. (3)



Sol. $\sum_{k=0}^6 {}^{51-k}C_3$

$$= {}^{51}C_3 + {}^{50}C_3 + {}^{49}C_3 + \dots + {}^{45}C_3$$

$$= {}^{45}C_3 + {}^{46}C_3 + \dots + {}^{51}C_3$$

$$= {}^{45}C_4 + {}^{45}C_3 + {}^{46}C_3 + \dots + {}^{51}C_3 - {}^{45}C_4$$

$$({}^nC_r + {}^nC_{r-1} = {}^{n+1}C_r)$$

$$= {}^{52}C_4 - {}^{45}C_4$$

75. The shortest distance between the lines $x+1=2y=12z$ and $x=y+2=6z-6$ is

- (1) 2 (2) 3
 (3) $\frac{5}{2}$ (4) $\frac{3}{2}$

Official Ans. by NTA (1)
Ans. (1)

Sol. $\frac{x+1}{1} = \frac{y}{2} = \frac{z}{12}$ and $\frac{x}{1} = \frac{y+2}{1} = \frac{z-1}{6}$

$$\Rightarrow \text{Shortest distance} = \frac{(\vec{b}-\vec{a}) \cdot (\vec{p} \times \vec{q})}{|\vec{p} \times \vec{q}|}$$

$$\text{S.D.} = \frac{(-\hat{i} + 2\hat{j} - \hat{k}) \cdot (\vec{p} \times \vec{q})}{|\vec{p} \times \vec{q}|}$$

$$\left\{ \vec{p} \times \vec{q} \equiv \begin{vmatrix} \hat{i} & \hat{j} & \hat{k} \\ 1 & \frac{1}{2} & \frac{-1}{12} \\ 1 & 1 & \frac{1}{6} \end{vmatrix} = \frac{1}{6}\hat{i} - \frac{1}{4}\hat{j} + \frac{1}{2}\hat{k} \text{ or } 2\hat{i} - 3\hat{j} + 6\hat{k} \right\}$$

$$\text{S.D.} = \frac{(-\hat{i} + 2\hat{j} - \hat{k}) \cdot (2\hat{i} - 3\hat{j} + 6\hat{k})}{\sqrt{2^2 + 3^2 + 6^2}} = \frac{-14}{7} = 2$$

76. Let N be the sum of the numbers appeared when two fair dice are rolled and let the probability that $N-2, \sqrt{3N}, N+2$ are in geometric progression

be $\frac{k}{48}$. Then the value of k is

- (1) 2 (2) 4
 (3) 16 (4) 8

Official Ans. by NTA (2)
Ans. (2)

Sol. $n(s) = 36$

Given : $N-2, \sqrt{3N}, N+2$ are in G.P.

$$3N = (N-2)(N+2)$$

$$3N = N^2 - 4$$

$$\Rightarrow N^2 - 3N - 4 = 0$$

$$(N-4)(N+1) = 0 \Rightarrow \boxed{N=4} \text{ or } N = -1 \text{ rejected}$$

$$(\text{Sum} = 4) \equiv \{(1, 3), (3, 1), (2, 2)\}$$

$$n(A) = 3$$

$$P(A) = \frac{3}{36} = \frac{1}{12} = \frac{4}{48} \Rightarrow \boxed{k=4}$$

77. The integral $16 \int_1^2 \frac{dx}{x^3(x^2+2)^2}$ is equal to

- (1) $\frac{11}{6} + \log_e 4$ (2) $\frac{11}{12} + \log_e 4$
 (3) $\frac{11}{12} - \log_e 4$ (4) $\frac{11}{6} - \log_e 4$

Official Ans. by NTA (4)

Ans. (4)

Sol. $I = 16 \int_1^2 \frac{dx}{x^3(x^2+2)^2}$

$$= 16 \int_1^2 \frac{dx}{x^3 x^4 \left(1 + \frac{2}{x^2}\right)^2}$$

Let, $1 + \frac{2}{x^2} = t \Rightarrow \frac{-4}{x^3} dx = dt$

$$I = -4 \int_3^{\frac{3}{2}} \frac{dt}{\left(\frac{2}{t-1}\right)^2 t^2}$$

$$I = -4 \int_3^{\frac{3}{2}} \left(\frac{t-1}{2}\right)^2 \frac{dt}{t^2}$$

$$I = -\frac{4}{4} \int_3^{\frac{3}{2}} \left(1 - \frac{2}{t} + \frac{1}{t^2}\right) dt$$



$$I = -1 \left[t - 2 \ln |t| - \frac{1}{t} \right]_3^{\frac{3}{2}}$$

$$I = -1 \left[\left(\frac{3}{2} - 2 \ln \frac{3}{2} - \frac{2}{3} \right) - \left(3 - 2 \ln 3 - \frac{1}{3} \right) \right]$$

$$I = -1 \left[2 \ln 2 - \frac{11}{6} \right]$$

$$I = \frac{11}{6} - \ln 4$$

78. Let T and C respectively be the transverse and conjugate axes of the hyperbola $16x^2 - y^2 + 64x + 4y + 44 = 0$. Then the area of the region above the parabola $x^2 = y + 4$, below the transverse axis T and on the right of the conjugate axis C is:

- (1) $4\sqrt{6} + \frac{44}{3}$ (2) $4\sqrt{6} + \frac{28}{3}$
 (3) $4\sqrt{6} - \frac{44}{3}$ (4) $4\sqrt{6} - \frac{28}{3}$

Official Ans. by NTA (2)

Ans. (2)

Sol. $16(x^2 + 4x) - (y^2 - 4y) + 44 = 0$

$$16(x + 2)^2 - 64 - (y - 2)^2 + 4 + 44 = 0$$

$$16(x + 2)^2 - (y - 2)^2 = 16$$

$$\frac{(x + 2)^2}{1} - \frac{(y - 2)^2}{16} = 1$$

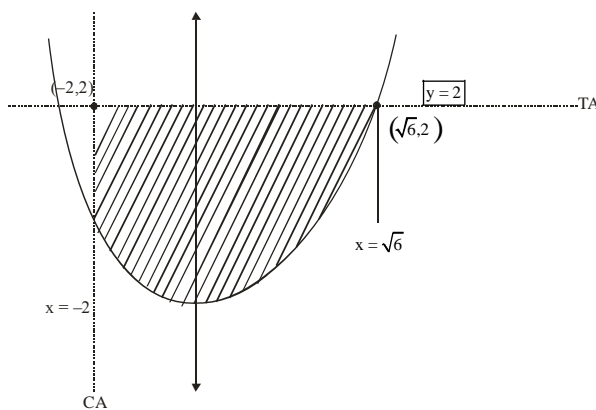

$$A = \int_{-2}^{\sqrt{6}} (2 - (x^2 - 4)) dx$$

$$A = \int_{-2}^{\sqrt{6}} (6 - x^2) dx = \left(6x - \frac{x^3}{3} \right)_{-2}^{\sqrt{6}}$$

$$A = \left(6\sqrt{6} - \frac{6\sqrt{6}}{3} \right) - \left(-12 + \frac{8}{3} \right)$$

$$A = \frac{12\sqrt{6}}{3} + \frac{28}{3}$$

$$A = 4\sqrt{6} + \frac{28}{3}$$

79. Let $\vec{a} = -\hat{i} - \hat{j} + \hat{k}$, $\vec{a} \cdot \vec{b} = 1$ and $\vec{a} \times \vec{b} = \hat{i} - \hat{j}$. Then $\vec{a} - 6\vec{b}$ is equal to

- (1) $3(\hat{i} - \hat{j} - \hat{k})$ (2) $3(\hat{i} + \hat{j} + \hat{k})$
 (3) $3(\hat{i} - \hat{j} + \hat{k})$ (4) $3(\hat{i} + \hat{j} - \hat{k})$

Official Ans. by NTA (2)

Ans. (2)

Sol. $\vec{a} \times \vec{b} = (\hat{i} - \hat{j})$

Taking cross product with \vec{a}

$$\Rightarrow \vec{a} \times (\vec{a} \times \vec{b}) = \vec{a} \times (\hat{i} - \hat{j})$$

$$\Rightarrow (\vec{a} \cdot \vec{b})\vec{a} - (\vec{a} \cdot \vec{a})\vec{b} = \hat{i} + \hat{j} + 2\hat{k}$$

$$\Rightarrow \vec{a} - 3\vec{b} = \hat{i} + \hat{j} + 2\hat{k}$$

$$\Rightarrow 2\vec{a} - 6\vec{b} = 2\hat{i} + 2\hat{j} + 4\hat{k}$$

$$\Rightarrow \vec{a} - 6\vec{b} = 3\hat{i} + 3\hat{j} + 3\hat{k}$$

80. The foot of perpendicular of the point (2, 0, 5) on the line $\frac{x+1}{2} = \frac{y-1}{5} = \frac{z+1}{-1}$ is (α, β, γ) . Then.

Which of the following is NOT correct?

- (1) $\frac{\alpha\beta}{\gamma} = \frac{4}{15}$ (2) $\frac{\alpha}{\beta} = -8$
 (3) $\frac{\beta}{\gamma} = -5$ (4) $\frac{\gamma}{\alpha} = \frac{5}{8}$

Official Ans. by NTA (3)

Ans. (3)



Sol. $L: \frac{x+1}{2} = \frac{y-1}{5} = \frac{z+1}{-1} = \lambda$ (let)

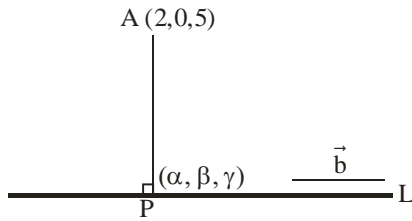

Let foot of perpendicular is

$$P(2\lambda - 1, 5\lambda + 1, -\lambda - 1)$$

$$\vec{PA} = (3 - 2\lambda)\hat{i} - (5\lambda + 1)\hat{j} + (6 + \lambda)\hat{k}$$

Direction ratio of line $\Rightarrow \vec{b} = 2\hat{i} + 5\hat{j} - \hat{k}$

Now, $\Rightarrow \vec{PA} \cdot \vec{b} = 0$

$$\Rightarrow 2(3 - 2\lambda) - 5(5\lambda + 1) - (6 + \lambda) = 0$$

$$\Rightarrow \lambda = \frac{-1}{6}$$

$$P(2\lambda - 1, 5\lambda + 1, -\lambda - 1) \equiv P(\alpha, \beta, \gamma)$$

$$\Rightarrow \alpha = 2\left(-\frac{1}{6}\right) - 1 = -\frac{4}{3} \Rightarrow \boxed{\alpha = -\frac{4}{3}}$$

$$\Rightarrow \beta = 5\left(-\frac{1}{6}\right) + 1 = \frac{1}{6} \Rightarrow \boxed{\beta = \frac{1}{6}}$$

$$\Rightarrow \gamma = -\lambda - 1 = \frac{1}{6} - 1 \Rightarrow \boxed{\gamma = -\frac{5}{6}}$$

\therefore Check options

SECTION-B

81. For the two positive numbers a, b, if a, b and $\frac{1}{18}$ are in a geometric progression, while $\frac{1}{a}$, 10 and $\frac{1}{b}$ are in an arithmetic progression, then, $16a + 12b$ is equal to _____.

Official Ans. by NTA 3

Ans. 3

Sol. $a, b, \frac{1}{18} \rightarrow GP$

$$\frac{a}{18} = b^2 \dots (i)$$

$$\frac{1}{a}, 10, \frac{1}{b} \rightarrow AP$$

$$\frac{1}{a} + \frac{1}{b} = 20$$

$$\Rightarrow a + b = 20ab, \text{ from eq. (i) ; we get}$$

$$\Rightarrow 18b^2 + b = 360b^3$$

$$\Rightarrow 360b^2 - 18b - 1 = 0 \quad \{\because b \neq 0\}$$

$$\Rightarrow b = \frac{18 \pm \sqrt{324 + 1440}}{720}$$

$$\Rightarrow b = \frac{18 + \sqrt{1764}}{720} \quad \{\because b > 0\}$$

$$\Rightarrow b = \frac{1}{12}$$

$$\Rightarrow a = 18 \times \frac{1}{144} = \frac{1}{8}$$

$$\text{Now, } 16a + 12b = 16 \times \frac{1}{8} + 12 \times \frac{1}{12} = 3$$

82. Points P(-3,2), Q(9,10) and R(α,4) lie on a circle C with PR as its diameter. The tangents to C at the points Q and R intersect at the point S. If S lies on the line $2x - ky = 1$, then k is equal to _____.

Official Ans. by NTA 3

Ans. 3

Sol. $m_{PQ} \cdot m_{QR} = -1$

$$\Rightarrow \frac{10-2}{9+3} \times \frac{10-4}{9-\alpha} = -1 \Rightarrow \boxed{\alpha = 13}$$

$$m_{OP} \cdot m_{QS} = -1 \Rightarrow m_{QS} = -\frac{4}{7}$$

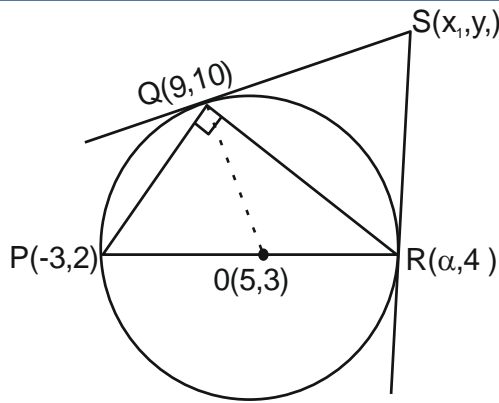

Equation of QS

$$y - 10 = -\frac{4}{7}(x - 9)$$

$$\Rightarrow 4x + 7y = 106 \dots(1)$$

$$m_{OR} \cdot m_{RS} = -1 \Rightarrow m_{RS} = -8$$

Equation of RS

$$y - 4 = -8(x - 13)$$

$$\Rightarrow 8x + y = 108 \dots(2)$$

Solving eq. (1) & (2)

$$x_1 = \frac{25}{2} \quad y_1 = 8$$

$S(x_1, y_1)$ lies on $2x - ky = 1$

$$25 - 8k = 1$$

$$\Rightarrow 8k = 24$$

$$\Rightarrow \boxed{k = 3}$$

83. Let $a \in \mathbb{R}$ and let α, β be the roots of the equation

$x^2 + 60^{\frac{1}{4}}x + a = 0$. If $\alpha^4 + \beta^4 = -30$, then the product of all possible values of a is _____.

Official Ans. by NTA 45

Ans. 45

Sol. $x^2 + 60^{\frac{1}{4}}x + a = 0 \begin{cases} \alpha \\ \beta \end{cases}$

$$\alpha + \beta = -60^{\frac{1}{4}} \quad \& \quad \alpha\beta = a$$

Given $\alpha^4 + \beta^4 = -30$

$$\Rightarrow (\alpha^2 + \beta^2)^2 - 2\alpha^2\beta^2 = -30$$

$$\Rightarrow \{(\alpha + \beta)^2 - 2\alpha\beta\}^2 - 2a^2 = -30$$

$$\Rightarrow \left\{60^{\frac{1}{2}} - 2a\right\}^2 - 2a^2 = -30$$

$$\Rightarrow 60 + 4a^2 - 4a \times 60^{\frac{1}{2}} - 2a^2 = -30$$

$$\Rightarrow 2a^2 - 4 \cdot 60^{\frac{1}{2}}a + 90 = 0$$

$$\text{Product} = \frac{90}{2} = 45$$

84. Suppose Anil's mother wants to give 5 whole fruits to Anil from a basket of 7 red apples, 5 white apples and 8 oranges. If in the selected 5 fruits, at least 2 orange, at least one red apple and at least one white apple must be given, then the number of ways, Anil's mother can offer 5 fruits to Anil is _____

Official Ans. by NTA 6860 OR 3

Sol. 7 Red apple(RA), 5 white apple(WA), 8 oranges (O) 5 fruits to be selected (Note:- fruits taken different) Possible selections :- (2O, 1RA, 2WA) or (2O, 2RA, 1WA) or (3O, 1RA, 1WA)

$$\Rightarrow {}^8C_2 {}^7C_1 {}^5C_2 + {}^8C_2 {}^7C_2 {}^5C_1 + {}^8C_3 {}^7C_1 {}^5C_1$$

$$\Rightarrow 1960 + 2940 + 1960$$

$$\Rightarrow 6860$$

85. If m and n respectively are the numbers of positive and negative value of θ in the interval $[-\pi, \pi]$ that satisfy the equation $\cos 2\theta \cos \frac{\theta}{2} = \cos 3\theta \cos \frac{9\theta}{2}$, then mn is equal to _____.

Official Ans. by NTA 25

Ans. 25



Sol. $\cos 2\theta \cdot \cos \frac{\theta}{2} = \cos 3\theta \cdot \cos \frac{9\theta}{2}$

$$\Rightarrow 2 \cos 2\theta \cdot \cos \frac{\theta}{2} = 2 \cos \frac{9\theta}{2} \cdot \cos 3\theta$$

$$\Rightarrow \cos \frac{5\theta}{2} + \cos \frac{3\theta}{2} = \cos \frac{15\theta}{2} + \cos \frac{3\theta}{2}$$

$$\Rightarrow \cos \frac{15\theta}{2} = \cos \frac{5\theta}{2}$$

$$\Rightarrow \frac{15\theta}{2} = 2k\pi \pm \frac{5\theta}{2}$$

$5\theta = 2k\pi$ or $10\theta = 2k\pi$

$\theta = \frac{2k\pi}{5}$ $\theta = \frac{k\pi}{5}$

$\therefore \theta = \left\{ -\pi, \frac{-4\pi}{5}, \frac{-3\pi}{5}, \frac{-2\pi}{5}, \frac{-\pi}{5}, 0, \frac{\pi}{5}, \frac{2\pi}{5}, \frac{3\pi}{5}, \frac{4\pi}{5}, \pi \right\}$

$m = 5, n = 5$

$\therefore m \cdot n = 25$

86. If $\int_{\frac{1}{3}}^3 |\log_e x| dx = \frac{m}{n} \log_e \left(\frac{n^2}{e} \right)$, where m and n are

coprime natural numbers, then $m^2 + n^2 - 5$ is equal to _____.

Official Ans. by NTA 20

Ans. 20

Sol. $\int_{\frac{1}{3}}^3 |\ln x| dx = \int_{\frac{1}{3}}^1 (-\ln x) dx + \int_1^3 (\ln x) dx$

$$= -[x \ln x - x]_{\frac{1}{3}}^1 + [x \ln x - x]_1^3$$

$$= -\left[-1 - \left(\frac{1}{3} \ln \frac{1}{3} - \frac{1}{3} \right) \right] + [3 \ln 3 - 3 - (-1)]$$

$$= \left[-\frac{2}{3} - \frac{1}{3} \ln \frac{1}{3} \right] + [3 \ln 3 - 2]$$

$$= -\frac{4}{3} + \frac{8}{3} \ln 3$$

$$= \frac{4}{3} (2 \ln 3 - 1)$$

$$= \frac{4}{3} \left(\ln \frac{9}{e} \right)$$

$\therefore m = 4, n = 3$

Now, $m^2 + n^2 - 5 = 16 + 9 - 5 = 20$

87. The remainder when $(2023)^{2023}$ is divided by 35 is _____.

Official Ans. by NTA 7

Ans. 7

Sol. $(2023)^{2023}$

$$= (2030 - 7)^{2023}$$

$$= (35K - 7)^{2023}$$

$$= {}^{2023}C_0 (35K)^{2023} (-7)^0 + {}^{2023}C_1 (35K)^{2022} (-7) + \dots + \dots + {}^{2023}C_{2023} (-7)^{2023}$$

$$= 35N - 7^{2023}$$

Now, $-7^{2023} = -7 \times 7^{2022} = -7 (7^2)^{1011}$

$= -7 (50 - 1)^{1011}$

$= -7 ({}^{1011}C_0 50^{1011} - {}^{1011}C_1 (50)^{1010} + \dots + {}^{1011}C_{1011})$

$= -7 (5\lambda - 1)$

$= -35\lambda + 7$

\therefore when $(2023)^{2023}$ is divided by 35 remainder is 7

88. If the shortest distance between the line joining the points (1, 2, 3) and (2, 3, 4), and the line $\frac{x-1}{2} = \frac{y+1}{-1} = \frac{z-2}{0}$ is α , then $28\alpha^2$ is equal to _____.

Official Ans. by NTA 18

Ans. 18

Sol. $\vec{r} = (\hat{i} + 2\hat{j} + 3\hat{k}) + \lambda(\hat{i} + \hat{j} + \hat{k})$ $\vec{r} = \vec{a} + \lambda\vec{p}$

$\vec{r} = (\hat{i} - \hat{j} + 2\hat{k}) + \mu(2\hat{i} - \hat{j})$ $\vec{r} = \vec{b} + \mu\vec{q}$

$$\vec{p} \times \vec{q} = \begin{vmatrix} \hat{i} & \hat{j} & \hat{k} \\ 1 & 1 & 1 \\ 2 & -1 & 0 \end{vmatrix} = \hat{i} + 2\hat{j} - 3\hat{k}$$

$$d = \frac{(\vec{b} - \vec{a}) \cdot (\vec{p} \times \vec{q})}{|\vec{p} \times \vec{q}|}$$

$$d = \frac{(-3\hat{j} - \hat{k}) \cdot (\hat{i} + 2\hat{j} - 3\hat{k})}{\sqrt{14}}$$

$$= \frac{-6 + 3}{\sqrt{14}} = \frac{3}{\sqrt{14}}$$

$$\alpha = \frac{3}{\sqrt{14}}$$

Now, $28\alpha^2 = 28 \times \frac{9}{14} = 18$



89. 25% of the population are smokers. A smoker has 27 times more chances to develop lung cancer than a non-smoker. A person is diagnosed with lung cancer and the probability that this person is a smoker is $\frac{k}{10}$. Then the value of k is _____.

Official Ans. by NTA 9

Ans. 9

Sol. E_1 : Smokers

$$P(E_1) = \frac{1}{4}$$

E_2 : non-smokers

$$P(E_2) = \frac{3}{4}$$

E : diagnosed with lung cancer

$$P(E/E_1) = \frac{27}{28}$$

$$P(E/E_2) = \frac{1}{28}$$

$$P(E_1/E) = \frac{P(E_1)P(E/E_1)}{P(E)}$$

$$= \frac{\frac{1}{4} \times \frac{27}{28}}{\frac{1}{4} \times \frac{27}{28} + \frac{3}{4} \times \frac{1}{28}} = \frac{27}{30} = \frac{9}{10}$$

$$K = 9$$

90. A triangle is formed by X – axis, Y– axis and the line $3x + 4y = 60$. Then the number of points P(a, b) which lie strictly inside the triangle, where a is an integer and b is a multiple of a, is _____.

Official Ans. by NTA 31

Ans. 31

Sol. If $x = 1, y = \frac{57}{4} = 14.25$

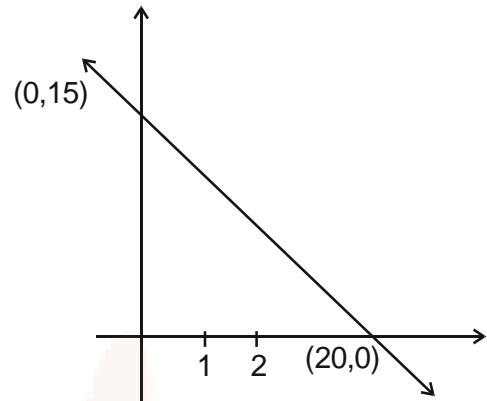

(1, 1) (1, 2) – (1, 14) \Rightarrow 14 pts.

If $x = 2, y = \frac{27}{2} = 13.5$

(2, 2) (2, 4) ... (2, 12) \Rightarrow 6 pts.

If $x = 3, y = \frac{51}{4} = 12.75$

(3, 3) (3, 6) – (3, 12) \Rightarrow 4 pts.

If $x = 4, y = 12$

(4, 4) (4, 8) \Rightarrow 2 pts.

If $x = 5, y = \frac{45}{4} = 11.25$

(5, 5), (5, 10) \Rightarrow 2 pts.

If $x = 6, y = \frac{21}{2} = 10.5$

(6, 6) \Rightarrow 1 pt.

If $x = 7, y = \frac{39}{4} = 9.75$

(7, 7) \Rightarrow 1 pt.

If $x = 8, y = 9$

(8, 8) \Rightarrow 1 pt.

If $x = 9, y = \frac{33}{4} = 8.25 \Rightarrow$ no pt.

Total = 31 pts.