

FINAL JEE-MAIN EXAMINATION – APRIL, 2019

(Held On Friday 12th APRIL, 2019) TIME : 9 : 30 AM To 12 : 30 PM

CHEMISTRY

TEST PAPER WITH ANSWER & SOLUTION

1. 5 moles of AB_2 weigh 125×10^{-3} kg and 10 moles of A_2B_2 weigh 300×10^{-3} kg. The molar mass of A (M_A) and molar mass of B (M_B) in kg mol^{-1} are :

- (1) $M_A = 50 \times 10^{-3}$ and $M_B = 25 \times 10^{-3}$
- (2) $M_A = 25 \times 10^{-3}$ and $M_B = 50 \times 10^{-3}$
- (3) $M_A = 5 \times 10^{-3}$ and $M_B = 10 \times 10^{-3}$
- (4) $M_A = 10 \times 10^{-3}$ and $M_B = 5 \times 10^{-3}$

Official Ans. by NTA (3)

Sol. $5[M_A + 2M_B] = 125$
 $M_A + 2M_B = 25$ (1)
 $2M_A + 2M_B = 30$ (2)
 from eq. (1) & (2)
 $M_A = 5$
 $M_B = 10$

2. The major product of the following addition reaction is :



- (1) $\text{H}_3\text{C}-\underset{\text{Cl}}{\text{CH}}-\underset{\text{OH}}{\text{CH}_2}$
- (2) $\text{H}_3\text{C}-\underset{\text{OH}}{\text{CH}}-\underset{\text{Cl}}{\text{CH}_2}$
- (3) $\text{H}_3\text{C}-\text{C}(\text{O})-\text{CH}_2$
- (4) $\text{H}_3\text{C}-\text{C}(\text{OH})-\text{CH}_3$

Official Ans. by NTA (2)

Sol. $\text{CH}_3-\text{CH}=\text{CH}_2 \xrightarrow{\text{Cl}_2/\text{H}_2\text{O}} \text{CH}_3-\overset{\oplus}{\text{C}}\text{H}-\text{CH}_2$

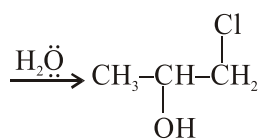

3. What is the molar solubility of $\text{Al}(\text{OH})_3$ in 0.2 M NaOH solution ? Given that, solubility product of $\text{Al}(\text{OH})_3 = 2.4 \times 10^{-24}$:

- (1) 12×10^{-23}
- (2) 12×10^{-21}
- (3) 3×10^{-19}
- (4) 3×10^{-22}

Official Ans. by NTA (4)

Sol. $\text{Al}(\text{OH})_3 \rightleftharpoons \text{Al}^{+3} + 3\text{OH}^-$

$$S' \quad 0.2 + 3(S') \approx 0.2$$

$$S' \times (0.2)^3 = k_{sp} = 2.4 \times 10^{-24}$$

$$(S') = 3 \times 10^{-22} \text{ M}$$

4. But-2-ene on reaction with alkaline KMnO_4 at elevated temperature followed by acidification will give :

(1) one molecule of CH_3CHO and one molecule of CH_3COOH

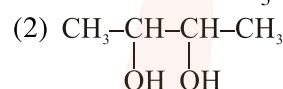

(3) 2 molecules of CH_3COOH

(4) 2 molecules of CH_3CHO

Official Ans. by NTA (3)

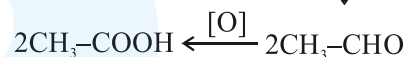
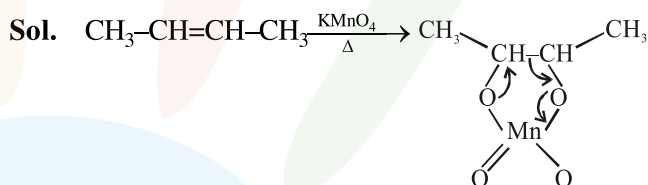

5. The correct sequence of thermal stability of the following carbonates is

- (1) $\text{BaCO}_3 < \text{CaCO}_3 < \text{SrCO}_3 < \text{MgCO}_3$
- (2) $\text{MgCO}_3 < \text{CaCO}_3 < \text{SrCO}_3 < \text{BaCO}_3$
- (3) $\text{BaCO}_3 < \text{SrCO}_3 < \text{CaCO}_3 < \text{MgCO}_3$
- (4) $\text{MgCO}_3 < \text{SrCO}_3 < \text{CaCO}_3 < \text{BaCO}_3$

Official Ans. by NTA (2)

Sol. Thermal stability of Alkaline earth metals carbonates increases down the group.

because down the group polarizing power of cation decreases. So thermal stability increases.

Hence, Thermal stability order :

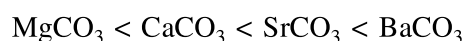

6. The correct statement among the following is
 (1) $(\text{SiH}_3)_3\text{N}$ is pyramidal and more basic than $(\text{CH}_3)_3\text{N}$
 (2) $(\text{SiH}_3)_3\text{N}$ is planar and more basic than $(\text{CH}_3)_3\text{N}$
 (3) $(\text{SiH}_3)_3\text{N}$ is pyramidal and less basic than $(\text{CH}_3)_3\text{N}$
 (4) $(\text{SiH}_3)_3\text{N}$ is planar and less basic than $(\text{CH}_3)_3\text{N}$

Official Ans. by NTA (4)

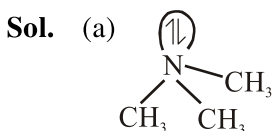

nitrogen is sp^3 hybrid and pyramidal
 no back-bonding i.e. more basic

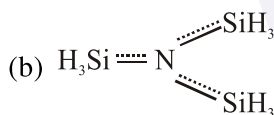

Nitrogen sp^2 hybrid and planar due to back bonding and less basic because lone pair is not available for donation.

7. Peptization is a :
 (1) process of converting a colloidal solution into precipitate
 (2) process of converting precipitate into colloidal solution
 (3) process of converting soluble particles to form colloidal solution
 (4) process of bringing colloidal molecule into solution

Official Ans. by NTA (2)

8. Given :
 $\text{Co}^{3+} + e^- \rightarrow \text{Co}^{2+} ; E^\circ = + 1.81 \text{ V}$
 $\text{Pb}^{4+} + 2e^- \rightarrow \text{Pb}^{2+} ; E^\circ = + 1.67 \text{ V}$
 $\text{Ce}^{4+} + e^- \rightarrow \text{Ce}^{3+} ; E^\circ = + 1.61 \text{ V}$
 $\text{Bi}^{3+} + 3e^- \rightarrow \text{Bi} ; E^\circ = + 0.20 \text{ V}$
 Oxidizing power of the species will increase in the order :
 (1) $\text{Ce}^{4+} < \text{Pb}^{4+} < \text{Bi}^{3+} < \text{Co}^{3+}$
 (2) $\text{Co}^{3+} < \text{Pb}^{4+} < \text{Ce}^{4+} < \text{Bi}^{3+}$
 (3) $\text{Co}^{3+} < \text{Ce}^{4+} < \text{Bi}^{3+} < \text{Pb}^{4+}$
 (4) $\text{Bi}^{3+} < \text{Ce}^{4+} < \text{Pb}^{4+} < \text{Co}^{3+}$

Official Ans. by NTA (4)

- Sol. $E^\circ_{\text{Red}} \uparrow \Rightarrow \text{oxidizing power} \uparrow$
 9. The metal that gives hydrogen gas upon treatment with both acid as well as base is :
 (1) zinc (2) iron
 (3) magnesium (4) mercury

Official Ans. by NTA (1)

- Sol. $\text{Zn} + 2\text{HCl} \rightarrow \text{ZnCl}_2 + \text{H}_2 \uparrow$
 $\text{Zn} + 2\text{NaOH} \rightarrow \text{Na}_2\text{ZnO}_2 + \text{H}_2 \uparrow$
 10. The group number, number of valence electrons, and valency of an element with atomic number 15, respectively, are
 (1) 16, 5 and 2 (2) 16, 6 and 3
 (3) 15, 5 and 3 (4) 15, 6 and 2

Official Ans. by NTA (3)

- Sol. Atomic number (Z) = 15 $\Rightarrow \text{P} \rightarrow [\text{Ne}] 3s^2 3p^3$
 Phosphorus belongs to 15th group
 number of valence electrons = 5
 and valency = 3 in ground state.
 11. The complex ion that will lose its crystal field stabilization energy upon oxidation of its metal to +3 state is

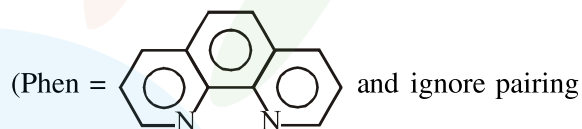

- (1) $[\text{Fe}(\text{phen})_3]^{2+}$ (2) $[\text{Zn}(\text{phen})_3]^{2+}$
 (3) $[\text{Ni}(\text{phen})_3]^{2+}$ (4) $[\text{Co}(\text{phen})_3]^{2+}$

Official Ans. by NTA (1)

- Sol. Phen = is a strong field symmetrical bidentate ligand.

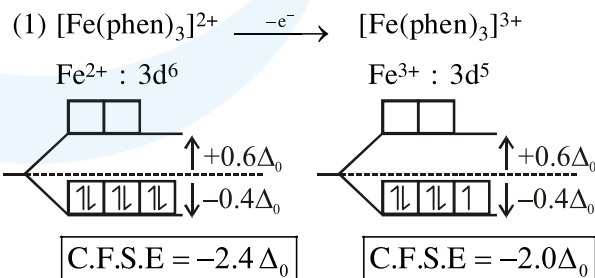

By oxidation of Fe^{2+} into Fe^{3+} , the CFSE value decrease.

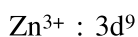
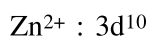
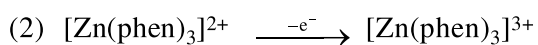

$\text{C.F.S.E} = 0$

$\text{C.F.S.E} = -0.6\Delta_0$

By oxidation of Zn^{2+} into Zn^{3+} , the CFSE value increase.

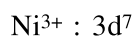
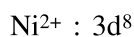
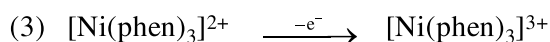

$\text{C.F.S.E} = -1.2\Delta_0$

$\text{C.F.S.E} = -1.8\Delta_0$

by oxidation of Ni^{2+} into Ni^{3+} , the CFSE value increase.

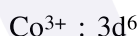
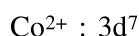
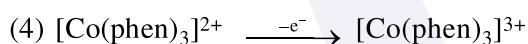

$\text{C.F.S.E} = -1.8\Delta_0$

$\text{C.F.S.E} = -2.4\Delta_0$

by oxidation of Co^{2+} into Co^{3+} , the CFSE value increase.

12. Complete removal of both the axial ligands (along the z-axis) from an octahedral complex leads to which of the following splitting patterns? (relative orbital energies not on scale).

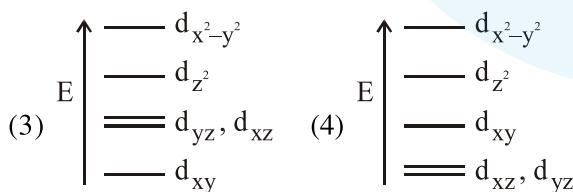
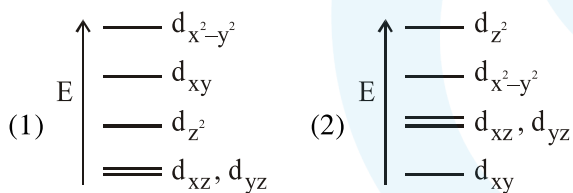

Official Ans. by NTA (1)

Sol. If both ligands present along z-axis removed from octahedral field and converted into square planar field, then

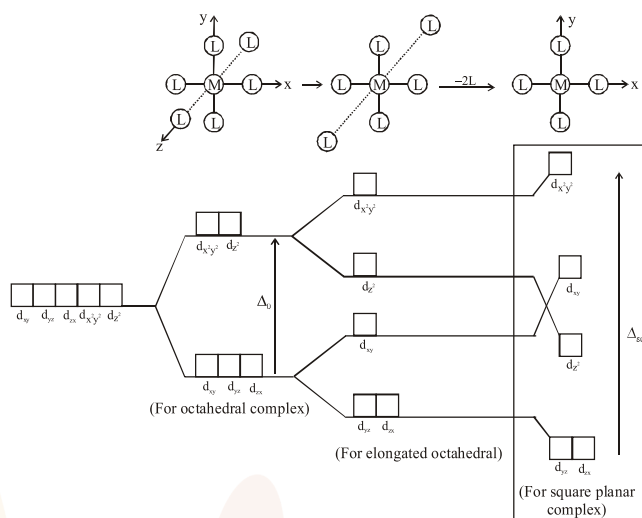

13. The major product(s) obtained in the following reaction is/are :

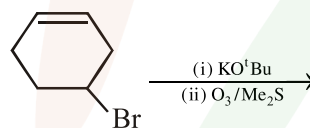

- (1) O=C\CCCC=CC=O
- (2) O=C\CCCC=O and O=C\O
- (3) O=C\CC(OBu)CC=O
- (4) O=C\CC=O

Official Ans. by NTA (2)

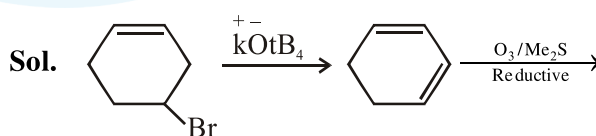

14. An element has a face-centred cubic (fcc) structure with a cell edge of a . The distance between the centres of two nearest tetrahedral voids in the lattice is :

- (1) $\frac{a}{2}$ (2) a
 (3) $\frac{3}{2}a$ (4) $\sqrt{2}a$

Official Ans. by NTA (1)

Sol. Distance between two nearest tetrahedral void
 $= \left(\frac{a}{2}\right)$

15. The major products of the following reaction are :

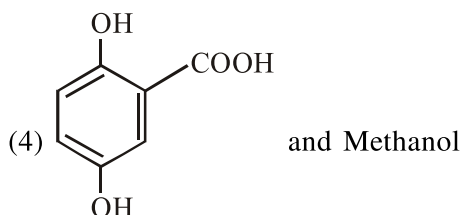
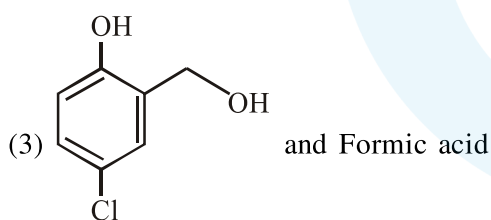
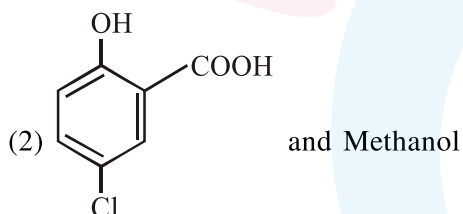
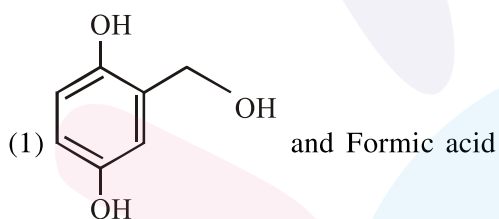
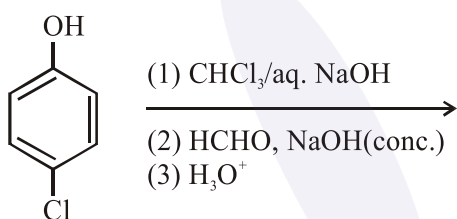

Official Ans. by NTA (3)

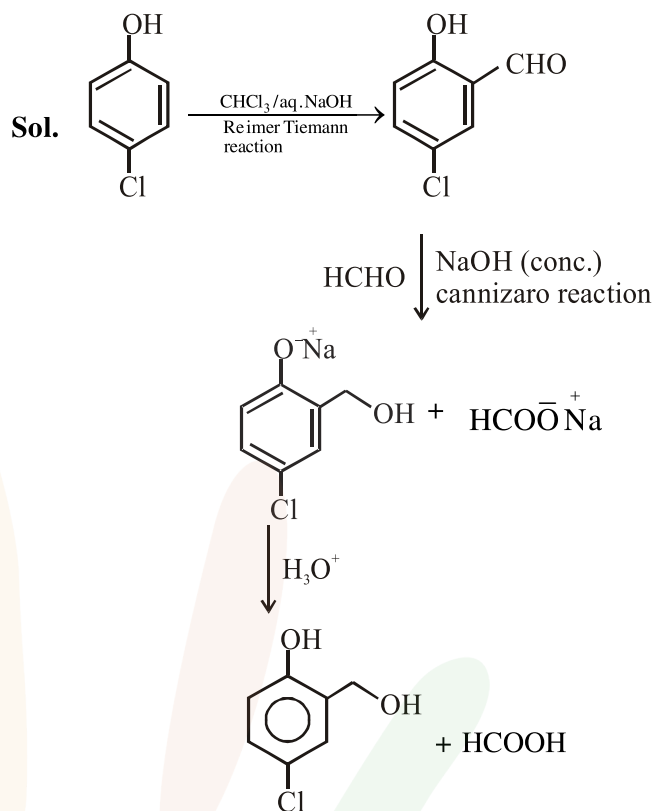

16. The increasing order of the pK_b of the following compound is :

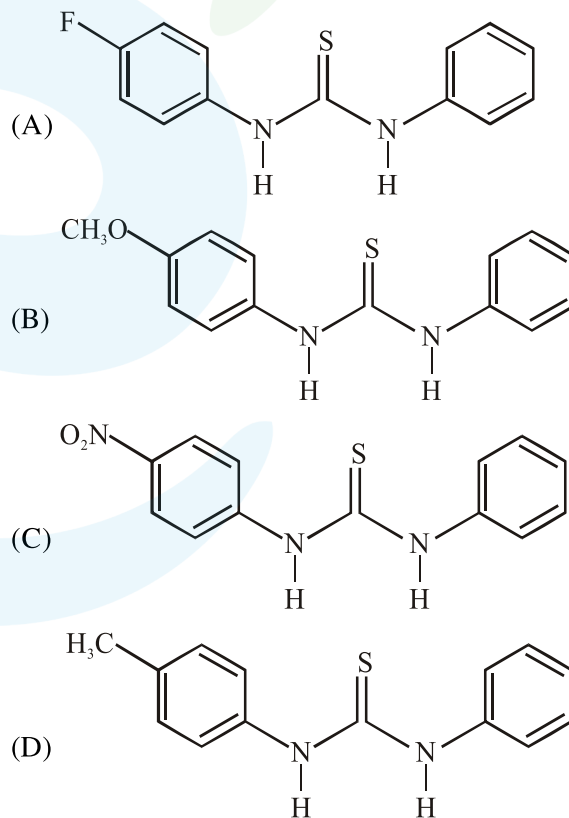

Options :

- (1) (A) < (C) < (D) < (B)
- (2) (B) < (D) < (A) < (C)
- (3) (C) < (A) < (D) < (B)
- (4) (B) < (D) < (C) < (A)

Official Ans. by NTA (2)

Sol. B < D < A < C

$$\text{Basicity} \propto +R \propto \frac{1}{-R}$$

$$\propto +H \propto \frac{1}{-H}$$

17. Which of the following statements is not true about RNA ?

- (1) It has always double stranded α -helix structure
- (2) It usually does not replicate
- (3) It is present in the nucleus of the cell
- (4) It controls the synthesis of protein

Official Ans. by NTA (1)

Sol. RNA is a single stranded structure.

18. In the following reaction; $xA \rightarrow yB$

$$\log_{10} \left[-\frac{d[A]}{dt} \right] = \log_{10} \left[\frac{d[B]}{dt} \right] + 0.3010$$

'A' and 'B' respectively can be :

- (1) n-Butane and Iso-butane
- (2) C_2H_4 and C_4H_8
- (3) N_2O_4 and NO_2
- (4) C_2H_2 and C_6H_6

Official Ans. by NTA (2)

Sol. $\log \frac{-d[A]}{dt} = \log \frac{d[B]}{dt} + 0.3010$

$$\frac{-d[A]}{dt} = 2 \times \frac{d[B]}{dt}$$

$$\frac{1}{2} \times \frac{-d[A]}{dt} = \frac{d[B]}{dt}$$

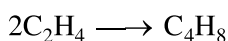
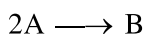

19. Glucose and Galactose are having identical configuration in all the positions except position.

- (1) C-3
- (2) C-2
- (3) C-4
- (4) C-5

Official Ans. by NTA (3)

Sol. Glucose and galactose are C-4 Epimer's

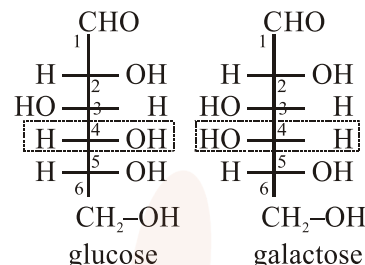

20. An ideal gas is allowed to expand from 1 L to 10 L against a constant external pressure of 1bar. The work done in kJ is :

- (1) -9.0
- (2) +10.0
- (3) -0.9
- (4) -2.0

Official Ans. by NTA (3)

Sol. $W = -P_{\text{ext}} (V_2 - V_1)$
 $= -1\text{bar} \times (10-1)\text{lit}$
 $= -9 \text{ bar-lit}$
 $= -900 \text{ J}$
 $= -0.9 \text{ kJ}$

21. Which of the following is a thermosetting polymer?

- (1) Buna-N
- (2) PVC
- (3) Bakelite
- (4) Nylon 6

Official Ans. by NTA (3)

Sol. Bakelite is thermosetting polymer

22. The idea of froth floatation method came from a person X and this method is related to the process Y of ores. X and Y, respectively, are:

- (1) fisher woman and concentration
- (2) washer man and reduction
- (3) washer woman and concentration
- (4) fisher man and reduction

Official Ans. by NTA (3)

Sol. The idea of froth floatation method came from washerwoman and this process is related to concentration of sulphide ores.

23. An example of a disproportionation reaction is :

- (1) $2\text{KMnO}_4 \rightarrow \text{K}_2\text{MnO}_4 + \text{MnO}_2 + \text{O}_2$
- (2) $2\text{MnO}_4^- + 10\text{I}^- + 16\text{H}^+ \rightarrow 2\text{Mn}^{2+} + 5\text{I}_2 + 8\text{H}_2\text{O}$
- (3) $2\text{CuBr} \rightarrow \text{CuBr}_2 + \text{Cu}$
- (4) $2\text{NaBr} + \text{Cl}_2 \rightarrow 2\text{NaCl} + \text{Br}_2$

Official Ans. by NTA (3)

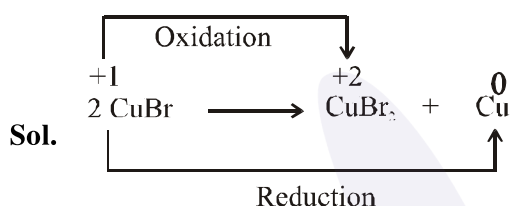

24. The correct set of species responsible for the photochemical smog is :

- (1) NO , NO_2 , O_3 and hydrocarbons
- (2) N_2 , O_2 , O_3 and hydrocarbons
- (3) N_2 , NO_2 and hydrocarbons
- (4) CO_2 , NO_2 , SO_2 and hydrocarbons

Official Ans. by NTA (1)

Sol. The common component of photochemical smog are ozone, nitric oxide, acrolein, formaldehyde and peroxyacetyl nitrate (PAN).

25. The electrons are more likely to be found :

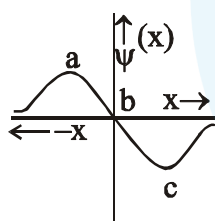

- (1) in the region a and b
- (2) in the region a and c
- (3) only in the region c
- (4) only in the region a

Official Ans. by NTA (2)

Sol. $P(x) = 4\pi x^2 \times [\Psi(x)]^2$

Probability will be maximum at a and c

26. The basic structural unit of feldspar, zeolites, mica, and asbestos is :

- (1) $(\text{SiO}_3)^{2-}$
- (2) SiO_2
- (3) $(\text{SiO}_4)^{4-}$
- (4) $(\text{Si}-\text{O})_n$ (R=Me)



Official Ans. by NTA (3)

Sol. Feldspar - KAlSi_3O_8 - $\text{NaAlSi}_3\text{O}_8$ - $\text{CaAl}_2\text{Si}_2\text{O}_8$

Zeolites - $\text{NaAlSi}_2\text{O}_6 \cdot \text{H}_2\text{O}$

mica - $\text{KAl}_3\text{Si}_3\text{O}_{10}(\text{OH})_2$

asbestos - $\text{Mg}_3\text{Si}_2\text{O}_5(\text{OH})_4$

These all are silicates having basic unit $(\text{SiO}_4)^{4-}$

27. An organic compound 'A' is oxidized with Na_2O_2 followed by boiling with HNO_3 . The resultant solution is then treated with ammonium molybdate to yield a yellow precipitate.

Based on above observation, the element present in the given compound is :

- (1) Sulphur
- (2) Nitrogen
- (3) Fluorine
- (4) Phosphorus

Official Ans. by NTA (4)

Sol. The phosphorus containing organic compound are detected by 'Lassaigne's test' by heated with an oxidizing agent (sodium peroxide)

The phosphorus present in the compound is oxidised to phosphate.

The solution is boiled with nitric acid and then treated with ammonium molybdate to produced canary yellow precipitate.

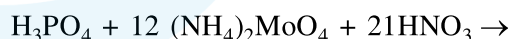
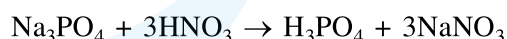

(Ammonium molybdate)

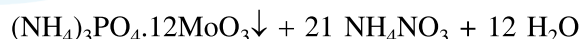

(Ammonium phosphomolybdate)

(canary yellow precipitate)

28. Enthalpy of sublimation of iodine is 24 cal g⁻¹ at 200°C. If specific heat of I₂(s) and I₂(vap) are 0.055 and 0.031 cal g⁻¹K⁻¹ respectively, then enthalpy of sublimation of iodine at 250°C in cal g⁻¹ is :

- (1) 2.85 (2) 11.4 (3) 5.7 (4) 22.8

Official Ans. by NTA (4)

Sol. I₂(s) → I₂(g): ΔH₁ = 24 cal/g at 200°C

$$\Delta H_2 = \Delta H_1 + \Delta C_{p_{\text{rxn}}} (T_2 - T_1)$$

$$= 24 + (0.031 - 0.055) \times 50$$

$$= 24 - 1.2$$

$$= 22.8 \text{ Cal/g}$$

29. The major product of the following reaction

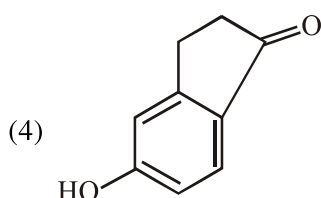
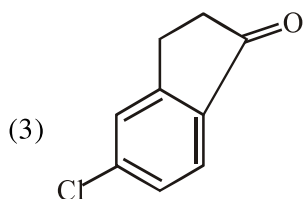
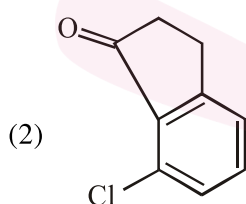
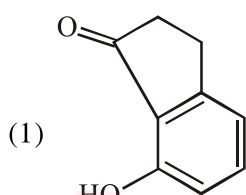
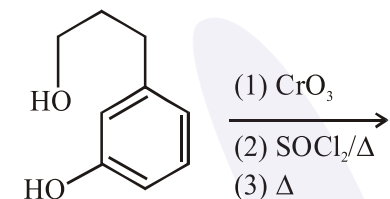

Official Ans. by NTA (4)

Sol.

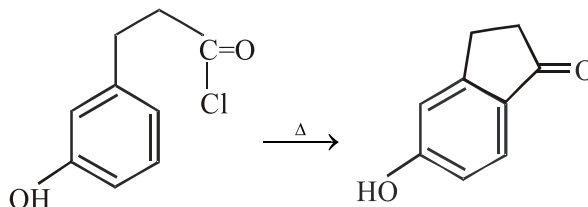
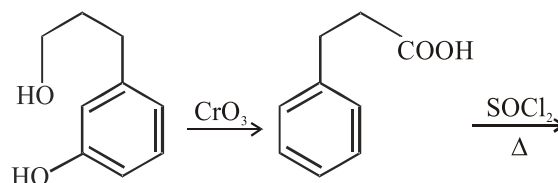

30. The mole fraction of a solvent in aqueous solution of a solute is 0.8. The molality (in mol kg⁻¹) of the aqueous solution is

- (1) 13.88 × 10⁻¹ (2) 13.88 × 10⁻²
 (3) 13.88 (4) 13.88 × 10⁻³

Official Ans. by NTA (3)

Sol. X_{solvent} = 0.8

If n_T = 1

n_{Solvent} = 0.8

n_{Solute} = 0.2

$$\text{molality} = \frac{0.2}{\frac{0.8 \times 18}{1000}} = 13.88$$