

**FINAL JEE-MAIN EXAMINATION – APRIL, 2019**

(Held On Wednesday 10<sup>th</sup> APRIL, 2019) TIME : 9 : 30 AM To 12 : 30 PM

**PHYSICS**

**TEST PAPER WITH ANSWER & SOLUTION**

1. Figure shows charge (q) versus voltage (V) graph for series and parallel combination of two given capacitors. The capacitances are :

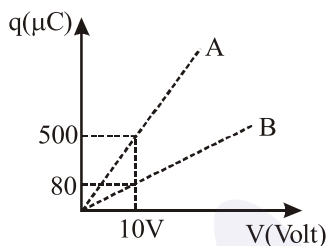

- (1) 50  $\mu\text{F}$  and 30  $\mu\text{F}$     (2) 20  $\mu\text{F}$  and 30  $\mu\text{F}$   
 (3) 60  $\mu\text{F}$  and 40  $\mu\text{F}$     (4) 40  $\mu\text{F}$  and 10  $\mu\text{F}$

**Official Ans. by NTA (4)**

**Sol.** As  $q = CV$

Hence slope of graph will give capacitance. Slope will be more in parallel combination. Hence capacitance in parallel should be 50  $\mu\text{F}$  & in series combination must be 8  $\mu\text{F}$ .

Only in option 40  $\mu\text{F}$  & 10  $\mu\text{F}$

$$C_{\text{parallel}} = 40 + 10 = 50 \mu\text{F}$$

$$C_{\text{series}} = \frac{40 \times 10}{40 + 10} = 8 \mu\text{F}$$

2. A current of 5 A passes through a copper conductor (resistivity =  $1.7 \times 10^{-8} \Omega\text{m}$ ) of radius of cross-section 5 mm. Find the mobility of the charges if their drift velocity is  $1.1 \times 10^{-3} \text{ m/s}$ .

- (1) 1.3  $\text{m}^2/\text{Vs}$                       (2) 1.5  $\text{m}^2/\text{Vs}$   
 (3) 1.8  $\text{m}^2/\text{Vs}$                       (4) 1.0  $\text{m}^2/\text{Vs}$

**Official Ans. by NTA (4)**

**Sol.**  $\mu = \frac{V_d}{E}$      $E = \rho J$

$$= \frac{1.1 \times 10^{-3}}{1.7 \times 10^{-8} \times \frac{5}{\pi \times 25 \times 10^{-6}}}$$

$$= \frac{1.1 \times 10^{-3} \times \pi \times 25 \times 10^{-6}}{1.7 \times 10^{-8} \times 5} \approx 1.01 \text{ m}^2 / \text{Vs}$$

3. In a meter bridge experiment, the circuit diagram and the corresponding observation table are shown in figure

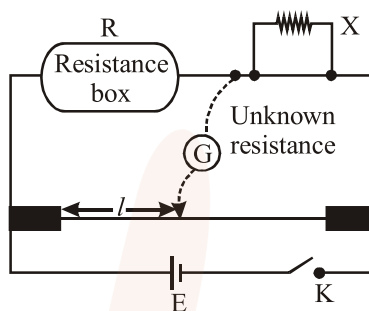

Sl. No.	R( $\Omega$ )	l(cm)
1.	1000	60
2.	100	13
3.	10	1.5
4.	1	1.0

Which of the readings is inconsistent?

- (1) 4                      (2) 1                      (3) 2                      (4) 3

**Official Ans. by NTA (1)**

**Sol.** as  $x = \frac{R(100 - \ell)}{\ell}$

for (1)     $x = \frac{1000 \times (100 - 60)}{40} \approx 667$

for (2)     $x = \frac{100 \times (100 - 13)}{13} \approx 669$

for (3)     $x = \frac{10 \times (100 - 1.5)}{98.5} \approx 656$

for (4)     $x = \frac{1 \times (100 - 1)}{1} \approx 99$

So option (4) is completely different hence correct Ans. (4)

4. One plano-convex and one plano-concave lens of same radius of curvature 'R' but of different materials are joined side by side as shown in the figure. If the refractive index of the material of 1 is  $\mu_1$  and that of 2 is  $\mu_2$ , then the focal length of the combination is :

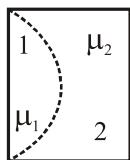

- (1)  $\frac{R}{2 - (\mu_1 - \mu_2)}$       (2)  $\frac{2R}{\mu_1 - \mu_2}$   
 (3)  $\frac{R}{2(\mu_1 - \mu_2)}$       (4)  $\frac{R}{\mu_1 - \mu_2}$

Official Ans. by NTA (4)

Sol. For 1<sup>st</sup> lens  $\frac{1}{f_1} = \left(\frac{\mu_1 - 1}{1}\right) \left(\frac{1}{\infty} - \frac{1}{-R}\right) = \frac{\mu_1 - 1}{R}$

for 2<sup>nd</sup> lens  $\frac{1}{f_2} = \left(\frac{\mu_2 - 1}{1}\right) \left(\frac{1}{-R} - 0\right) = -\frac{\mu_2 - 1}{R}$

$$\frac{1}{f_{eq}} = \frac{1}{f_1} + \frac{1}{f_2}$$

$$\frac{1}{f_{eq}} = \frac{R}{\mu_1 - 1} + \frac{R}{-(\mu_2 - 1)} \Rightarrow \frac{1}{f_{eq}} = \frac{R}{\mu_1 - \mu_2}$$

Hence  $f_{eq} = \frac{\mu_1 - \mu_2}{R}$

5. A ball is thrown upward with an initial velocity  $V_0$  from the surface of the earth. The motion of the ball is affected by a drag force equal to  $m\gamma v^2$  (where  $m$  is mass of the ball,  $v$  is its instantaneous velocity and  $\gamma$  is a constant). Time taken by the ball to rise to its zenith is :

(1)  $\frac{1}{\sqrt{\gamma g}} \sin^{-1} \left( \sqrt{\frac{\gamma}{g}} V_0 \right)$

(2)  $\frac{1}{\sqrt{\gamma g}} \tan^{-1} \left( \sqrt{\frac{\gamma}{g}} V_0 \right)$

(3)  $\frac{1}{\sqrt{2\gamma g}} \tan^{-1} \left( \sqrt{\frac{2\gamma}{g}} V_0 \right)$

(4)  $\frac{1}{\sqrt{\gamma g}} \ln \left( 1 + \sqrt{\frac{\gamma}{g}} V_0 \right)$

Official Ans. by NTA (2)

Sol.  $-(g + \gamma v^2) = \frac{dv}{dt}$

$$-g dt = \frac{g}{\gamma} \left( \frac{dv}{\frac{g}{\gamma} + v^2} \right)$$

Integrating  $0 \rightarrow t$  &  $V_0 \rightarrow 0$  :-

$$-gt = -\sqrt{\frac{g}{\gamma}} \tan^{-1} \left( \frac{V_0}{\sqrt{\frac{g}{\gamma}}} \right)$$

$$t = \frac{1}{\sqrt{\gamma g}} \tan^{-1} \left( \sqrt{\frac{\gamma}{g}} V_0 \right)$$

6. A cylinder with fixed capacity of 67.2 lit contains helium gas at STP. The amount of heat needed to raise the temperature of the gas by  $20^\circ\text{C}$  is : [Given that  $R = 8.31 \text{ J mol}^{-1} \text{ K}^{-1}$ ]  
 (1) 748 J    (2) 374 J    (3) 350 J    (4) 700 J

Official Ans. by NTA (1)

Sol.  $\Delta Q = nC_V \Delta T = n \frac{3}{2} R \Delta T$

$$= \left( \frac{67.2}{22.4} \right) \left( \frac{3}{2} \times 8.31 \right) (20)$$

$$\approx 748 \text{ J}$$

7. A thin disc of mass  $M$  and radius  $R$  has mass per unit area  $\sigma(r) = kr^2$  where  $r$  is the distance from its centre. Its moment of inertia about an axis going through its centre of mass and perpendicular to its plane is :

(1)  $\frac{MR^2}{6}$       (2)  $\frac{MR^2}{3}$

(3)  $\frac{2MR^2}{3}$       (4)  $\frac{MR^2}{2}$

Official Ans. by NTA (3)

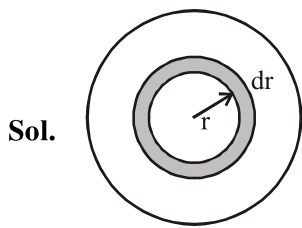

Sol.

$$I_{\text{Disc}} = \int_0^R (dm)r^2 \Rightarrow I_{\text{Disc}} = \int_0^R (\sigma 2\pi r dr)r^2$$

$$I_{\text{Disc}} = \int_0^R (kr^2 2\pi r dr)r^2 \quad \text{Mass of disc}$$

$$I_{\text{Disc}} = 2\pi k \int_0^R r^5 dr \quad M = \int_0^R 2\pi r dr kr^2$$

$$I_{\text{Disc}} = 2\pi k \left( \frac{r^6}{6} \right)_0^R \quad M = 2\pi k \int_0^R r^3 dr$$

$$I_{\text{Disc}} = 2\pi k \frac{R^6}{6} \quad M = 2\pi k \frac{r^4}{4} \Big|_0^R$$

$$I_{\text{Disc}} = \frac{\pi k R^6}{3} = \left( \frac{\pi k R^4}{2} \right) \frac{R^2 2}{3} \quad M = 2\pi k \frac{R^4}{4}$$

$$I_{\text{Disc}} = \frac{M 2R^2}{3}$$

$$I_{\text{Disc}} = \frac{2}{3} MR^2$$

8. Two coaxial discs, having moments of inertia

$I_1$  and  $\frac{I_1}{2}$ , are rotating with respective angular

velocities  $\omega_1$  and  $\frac{\omega_1}{2}$ , about their common axis.

They are brought in contact with each other and thereafter they rotate with a common angular velocity. If  $E_f$  and  $E_i$  are the final and initial total energies, then  $(E_f - E_i)$  is :

(1)  $\frac{I_1 \omega_1^2}{12}$                       (2)  $\frac{3}{8} I_1 \omega_1^2$

(3)  $\frac{I_1 \omega_1^2}{6}$                          (4)  $\frac{I_1 \omega_1^2}{24}$

Official Ans. by NTA (4)

Sol.  $E_i = \frac{1}{2} I_1 \times \omega_1^2 + \frac{1}{2} \frac{I_1}{2} \times \frac{\omega_1^2}{4}$

$$= \frac{I_1 \omega_1^2}{2} \left( \frac{9}{8} \right) = \frac{9}{16} I_1 \omega_1^2$$

$$I_1 \omega_1 + \frac{I_1 \omega_1}{4} = \frac{3I_1}{2} \omega$$

$$\frac{5}{4} I_1 \omega_1 = \frac{3I_1}{2} \omega$$

$$\omega = \frac{5}{6} \omega_1$$

$$E_f = \frac{1}{2} \times \frac{3I_1}{2} \times \frac{25}{36} \omega_1^2$$

$$= \frac{25}{48} I_1 \omega_1^2$$

$$\Rightarrow E_f - E_i = I_1 \omega_1^2 \left( \frac{25}{48} - \frac{9}{16} \right) = \frac{-2}{48} I_1 \omega_1^2$$

$$= \frac{-I_1 \omega_1^2}{24}$$

9. A particle of mass  $m$  is moving along a trajectory given by

$$x = x_0 + a \cos \omega_1 t$$

$$y = y_0 + b \sin \omega_2 t$$

The torque, acting on the particle about the origin, at  $t = 0$  is :

(1)  $m (-x_0 b + y_0 a) \omega_1^2 \hat{k}$

(2)  $+m y_0 a \omega_1^2 \hat{k}$

(3)  $-m (x_0 b \omega_2^2 - y_0 a \omega_1^2) \hat{k}$

(4) Zero

Official Ans. by NTA (2)

Sol.  $\vec{F} = -m (a \omega_1^2 \cos \omega_1 t \hat{i} + b \omega_2^2 \sin \omega_2 t \hat{j})$

$$\vec{r} = (x_0 + a \cos \omega_1 t) \hat{i} + (y_0 + b \sin \omega_2 t) \hat{j}$$

$$\vec{T} = \vec{r} \times \vec{F} = -m (x_0 + a \cos \omega_1 t) b \omega_2^2 \sin \omega_2 t \hat{k}$$

$$+ m (y_0 + b \sin \omega_2 t) a \omega_1^2 \cos \omega_1 t \hat{k}$$

$$= m a \omega_1^2 y_0 \hat{k}$$

10. A proton, an electron, and a Helium nucleus, have the same energy. They are in circular orbits in a plane due to magnetic field perpendicular to the plane. Let  $r_p$ ,  $r_e$  and  $r_{He}$  be their respective radii, then,

- (1)  $r_e > r_p > r_{He}$                       (2)  $r_e < r_p < r_{He}$   
 (3)  $r_e < r_p = r_{He}$                       (4)  $r_e > r_p = r_{He}$

Official Ans. by NTA (3)

Sol.  $r = \frac{mv}{qB} = \frac{\sqrt{2mK}}{qB}$

$r_{He} = r_p > r_e$

11. The electric field of a plane electromagnetic wave is given by

$\vec{E} = E_0 \hat{i} \cos(kz) \cos(\omega t)$

The corresponding magnetic field  $\vec{B}$  is then given by :

(1)  $\vec{B} = \frac{E_0}{C} \hat{j} \sin(kz) \cos(\omega t)$

(2)  $\vec{B} = \frac{E_0}{C} \hat{j} \sin(kz) \sin(\omega t)$

(3)  $\vec{B} = \frac{E_0}{C} \hat{k} \sin(kz) \cos(\omega t)$

(4)  $\vec{B} = \frac{E_0}{C} \hat{j} \cos(kz) \sin(\omega t)$

Official Ans. by NTA (2)

Sol.  $\therefore \vec{E} \times \vec{B} \parallel \vec{v}$

Given that wave is propagating along positive z-axis and  $\vec{E}$  along positive x-axis. Hence  $\vec{B}$  along y-axis.

From Maxwell equation

$\vec{\nabla} \times \vec{E} = -\frac{\partial \vec{B}}{\partial t}$

i.e.  $\frac{\partial E}{\partial z} = -\frac{\partial B}{\partial t}$  and  $B_0 = \frac{E_0}{C}$

12. Two wires A & B are carrying currents  $I_1$  &  $I_2$  as shown in the figure. The separation between them is  $d$ . A third wire C carrying a current  $I$  is to be kept parallel to them at a distance  $x$  from A such that the net force acting on it is zero. The possible values of  $x$  are :

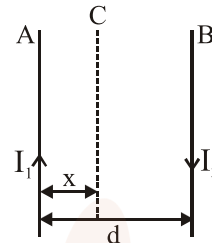

(1)  $x = \left(\frac{I_1}{I_1 - I_2}\right)d$  and  $x = \frac{I_2}{(I_1 + I_2)}d$

(2)  $x = \pm \frac{I_1 d}{(I_1 - I_2)}$

(3)  $x = \left(\frac{I_1}{I_1 + I_2}\right)d$  and  $x = \frac{I_2}{(I_1 - I_2)}d$

(4)  $x = \left(\frac{I_2}{I_1 + I_2}\right)d$  and  $x = \left(\frac{I_2}{I_1 - I_2}\right)d$

Official Ans. by NTA (2)

Sol.

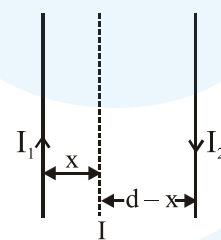

Net force on wire carrying current  $I$  per unit length is

$\frac{\mu_0 I_1 I}{2\pi x} + \frac{\mu_0 I_2 I}{2\pi(d-x)} = 0$

$\frac{I_1}{x} = -\frac{I_2}{x-d}$

$\Rightarrow x = \frac{I_1 d}{I_1 - I_2}$

13. A message signal of frequency 100 MHz and peak voltage 100 V is used to execute amplitude modulation on a carrier wave of frequency 300 GHz and peak voltage 400 V. The modulation index and difference between the two side band frequencies are :

- (1) 4;  $1 \times 10^8$  Hz      (2) 0.25;  $1 \times 10^8$  Hz  
 (3) 4;  $2 \times 10^8$  Hz      (4) 0.25;  $2 \times 10^8$  Hz

Official Ans. by NTA (4)

Sol.  $f_m = 100 \text{ MHz} = 10^8 \text{ Hz}$ ,  $(V_m)_0 = 100\text{V}$   
 $f_c = 300 \text{ GHz}$ ,  $(V_c)_0 = 400\text{V}$

$$\text{Modulation Index} = \frac{(V_m)_0}{(V_c)_0} = \frac{100}{400} = \frac{1}{4} = 0.25$$

$$\text{Upper band frequency (UBF)} = f_c + f_m$$

$$\text{Lower band frequency (LBF)} = f_c - f_m$$

$$\therefore \text{UBF} - \text{LBF} = 2f_m = 2 \times 10^8 \text{ Hz}$$

14. In an experiment, the resistance of a material is plotted as a function of temperature (in some range). As shown in the figure, it is a straight line. One may conclude that :

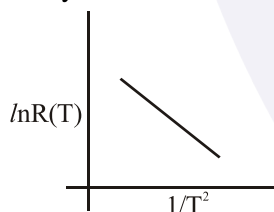

(1)  $R(T) = \frac{R_0}{T^2}$

(2)  $R(T) = R_0 e^{-T^2/T_0^2}$

(3)  $R(T) = R_0 e^{-T_0^2/T^2}$

(4)  $R(T) = R_0 e^{T^2/T_0^2}$

Official Ans. by NTA (3)

Sol.  $\frac{1}{T^2} + \frac{\ln R(T)}{\ln R(T_0)} = 1$

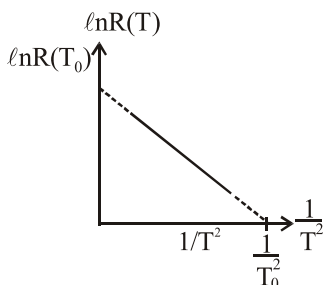

$$\Rightarrow \ln R(T) = [\ln R(T_0)] \left( 1 - \frac{T_0^2}{T^2} \right)$$

$$\Rightarrow R(T) = R_0 e^{\left( \frac{T_0^2}{T^2} \right)}$$

15. A ray of light AO in vacuum is incident on a glass slab at angle  $60^\circ$  and refracted at angle  $30^\circ$  along OB as shown in the figure. The optical path length of light ray from A to B is :

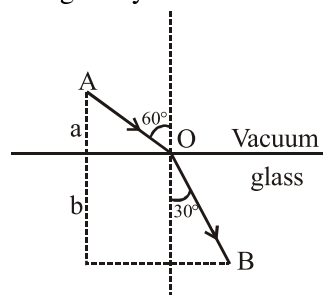

(1)  $2a + 2b$       (2)  $2a + \frac{2b}{3}$

(3)  $\frac{2\sqrt{3}}{a} + 2b$       (4)  $2a + \frac{2b}{\sqrt{3}}$

Official Ans. by NTA (1)

Sol. From Snell's law  
 $1 \cdot \sin 60^\circ = \mu \sin 30^\circ$

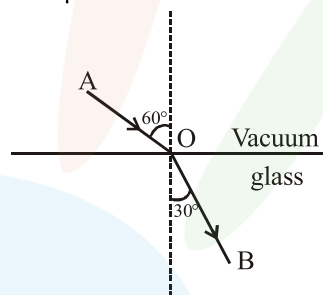

$$\Rightarrow \mu = \sqrt{3}$$

$$\text{Optical path} = AO + \mu(OB)$$

$$= \frac{a}{\cos 60^\circ} + \sqrt{3} \frac{b}{\cos 30^\circ}$$

$$= 2a + 2b$$

16. A transformer consisting of 300 turns in the primary and 150 turns in the secondary gives output power of 2.2 kW. If the current in the secondary coil is 10A, then the input voltage and current in the primary coil are :

- (1) 220 V and 10A  
 (2) 440 V and 5A  
 (3) 440 V and 20 A  
 (4) 220 V and 20 A

Official Ans. by NTA (2)

Sol. Given  $N_p = 300$ ,  $N_s = 150$ ,  $P_0 = 2200\text{W}$

$$I_s = 10\text{A}$$

$$P_0 = V_0 I_0 \Rightarrow 2200 = V_0 \times 10 \Rightarrow V_0 = 220\text{V}$$

$$\therefore \frac{V_i}{V_0} = \frac{N_p}{N_s} \Rightarrow V_i = 2 \times 220 = 440\text{V}$$

Also  $P_0 = V_i I_i$

$$\Rightarrow I_i = \frac{2200}{440} = 5\text{A}$$

17. In a photoelectric effect experiment the threshold wavelength of the light is 380 nm. If the wavelength of incident light is 260 nm, the maximum kinetic energy of emitted electrons will be:

$$\text{Given } E \text{ (in eV)} = \frac{1237}{\lambda \text{ (in nm)}}$$

- (1) 1.5 eV                      (2) 4.5 eV  
(3) 15.1 eV                    (4) 3.0 eV

**Official Ans. by NTA (1)**

**Sol.**  $K_{\max} = \frac{hc}{\lambda} - \frac{hc}{\lambda_0}$

$$\Rightarrow K_{\max} = hc \left( \frac{\lambda_0 - \lambda}{\lambda \lambda_0} \right)$$

$$\Rightarrow K_{\max} = (1237) \left( \frac{380 - 260}{380 \times 260} \right) = 1.5 \text{ eV}$$

18. The displacement of a damped harmonic oscillator is given by

$$x(t) = e^{-0.1t} \cos(10\pi t + \phi). \text{ Here } t \text{ is in seconds.}$$

The time taken for its amplitude of vibration to drop to half of its initial value is close to :

- (1) 13 s    (2) 7 s    (3) 27 s    (4) 4 s

**Official Ans. by NTA (2)**

**Sol.**  $A = A_0 e^{-0.1t} = \frac{A_0}{2}$

$$\ln 2 = 0.1t$$

$$t = 10 \ln 2 = 6.93 \approx 7 \text{ sec}$$

19. A moving coil galvanometer allows a full scale current of  $10^{-4}$  A. A series resistance of 2 M $\Omega$  is required to convert the above galvanometer into a voltmeter of range 0-5 V. Therefore the value of shunt resistance required to convert the above galvanometer into an ammeter of range 0-10 mA is :

- (1) 200  $\Omega$                       (2) 100  $\Omega$   
(3) 10  $\Omega$                         (4) 500  $\Omega$

**Official Ans. by NTA (Dropped)**

**Sol.**  $200 + 10^{-4} G = 5$

$$G = -ve$$

So answer is Bonus

20. A stationary source emits sound waves of frequency 500 Hz. Two observers moving along a line passing through the source detect sound to be of frequencies 480 Hz and 530 Hz. Their respective speeds are, in  $\text{ms}^{-1}$ ,

(Given speed of sound = 300 m/s)

- (1) 16, 14                      (2) 12, 18  
(3) 12, 16                      (4) 8, 18

**Official Ans. by NTA (2)**

**Sol.**  $f = 480 = \frac{300 - v_1}{300} \times 500$

$$\frac{1440}{5} = 300 - v_1$$

$$v_1 = \frac{60}{5} = 12 \text{ m/s}$$

$$530 = \frac{300 + v_2}{300} \times 500$$

$$1590 = 1500 + 5v_2$$

$$5v_2 = 90$$

$$v_2 = 18 \text{ m/s}$$

21. Two radioactive materials A and B have decay constants  $10\lambda$  and  $\lambda$ , respectively. It initially they have the same number of nuclei, then the ratio of the number of nuclei of A to that of B will be  $1/e$  after a time :

(1)  $\frac{11}{10\lambda}$                       (2)  $\frac{1}{9\lambda}$

(3)  $\frac{1}{10\lambda}$                       (4)  $\frac{1}{11\lambda}$

**Official Ans. by NTA (2)**

**Sol.**  $N_1 = N_0 e^{-10\lambda t}$

$$N_2 = N_0 e^{-\lambda t}$$

$$\frac{1}{e} = \frac{N_1}{N_2} = e^{-9\lambda t}$$

$$\Rightarrow 9\lambda t = 1$$

$$t = \frac{1}{9\lambda}$$

22. An npn transistor operates as a common emitter amplifier, with a power gain of 60 dB. The input circuit resistance is  $100\Omega$  and the output load resistance is  $10\text{ k}\Omega$ . The common emitter current gain  $\beta$  is :

- (1) 60 (2)  $10^4$   
 (3)  $6 \times 10^2$  (4)  $10^2$

Official Ans. by NTA (4)

Sol.  $A_v \times \beta = P_{\text{gain}}$

$$60 = 10 \log_{10} \left( \frac{P}{P_0} \right)$$

$$P = 10^6 = \beta^2 \times \frac{R_{\text{out}}}{R_{\text{in}}}$$

$$= \beta^2 \times \frac{10^4}{100}$$

$$\beta^2 = 10^4$$

$$\beta = 100$$

23. In the given circuit, an ideal voltmeter connected across the  $10\Omega$  resistance reads 2V. The internal resistance  $r$ , of each cell is :

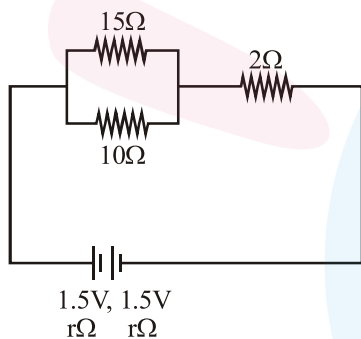

- (1)  $1\Omega$  (2)  $1.5\Omega$   
 (3)  $0\Omega$  (4)  $0.5\Omega$

Official Ans. by NTA (4)

Sol.  $R_{\text{eq}} = \frac{15 \times 10}{25} + 2 + 2r$

$$= 8 + 2r$$

$$i = \frac{3}{8 + 2r}$$

$$2 = i R_{\text{eq}} = \frac{3}{8 + 2r} \times 6$$

$$16 + 4r = 18$$

$$\Rightarrow r = 0.5\Omega$$

24. A  $25 \times 10^{-3}\text{ m}^3$  volume cylinder is filled with 1 mol of  $\text{O}_2$  gas at room temperature (300K). The molecular diameter of  $\text{O}_2$ , and its root mean square speed, are found to be 0.3 nm, and 200 m/s, respectively. What is the average collision rate (per second) for an  $\text{O}_2$  molecule ?

- (1)  $\sim 10^{11}$  (2)  $\sim 10^{13}$   
 (3)  $\sim 10^{10}$  (4)  $\sim 10^{12}$

Official Ans. by NTA (4)

Allen Ans. (3)

Sol.  $v = \frac{V_{\text{av}}}{\lambda}$

$$\lambda = \frac{RT}{\sqrt{2}\pi\sigma^2 N_A P}$$

$$\sigma = 2 \times .3 \times 10^{-9}$$

$$P = \frac{RT}{V}$$

$$\Rightarrow \lambda = \frac{V}{\sqrt{2}\pi\sigma^2 N_A}$$

$$V_{\text{av}} = \sqrt{\frac{8}{3\pi}} \times V_{\text{rms}}$$

$$\therefore v = \frac{200 \times \sqrt{2}\pi \times \sigma^2 N_A}{25 \times 10^{-3}} \times \sqrt{\frac{8}{3\pi}}$$

$$= 17.68 \times 10^8/\text{sec.}$$

$$= .1768 \times 10^{10}/\text{sec.} \sim 10^{10}$$

This answer does not match with JEE-Answer key

25.  $n$  moles of an ideal gas with constant volume heat capacity  $C_v$  undergo an isobaric expansion by certain volume. The ratio of the work done in the process, to the heat supplied is :

(1)  $\frac{4nR}{C_v - nR}$  (2)  $\frac{nR}{C_v - nR}$

(3)  $\frac{nR}{C_v + nR}$  (4)  $\frac{4nR}{C_v + nR}$

Official Ans. by NTA (3)

Sol.  $w = nR\Delta T$

$$\Delta H = (C_v + nR) \Delta T$$

$$\frac{w}{\Delta H} = \frac{nR}{C_v + nR}$$

**Final JEE-Main Exam April, 2019/10-04-2019/Morning Session**

26. A uniformly charged ring of radius  $3a$  and total charge  $q$  is placed in  $xy$ -plane centred at origin. A point charge  $q$  is moving towards the ring along the  $z$ -axis and has speed  $u$  at  $z = 4a$ . The minimum value of  $u$  such that it crosses the origin is :

(1)  $\sqrt{\frac{2}{m} \left( \frac{1}{15} \frac{q^2}{4\pi\epsilon_0 a} \right)^{1/2}}$

(2)  $\sqrt{\frac{2}{m} \left( \frac{2}{15} \frac{q^2}{4\pi\epsilon_0 a} \right)^{1/2}}$

(3)  $\sqrt{\frac{2}{m} \left( \frac{4}{15} \frac{q^2}{4\pi\epsilon_0 a} \right)^{1/2}}$

(4)  $\sqrt{\frac{2}{m} \left( \frac{1}{5} \frac{q^2}{4\pi\epsilon_0 a} \right)^{1/2}}$

**Official Ans. by NTA (2)**

**Sol.**  $U_i + K_i = U_f + K_f$

$$\frac{kq^2}{\sqrt{16a^2 + 9a^2}} + \frac{1}{2}mv^2 = \frac{kq^2}{3a}$$

$$\frac{1}{2}mv^2 = \frac{kq^2}{a} \left( \frac{1}{3} - \frac{1}{5} \right) = \frac{2kq^2}{15a}$$

$$v = \sqrt{\frac{4kq^2}{15ma}}$$

27. The value of acceleration due to gravity at Earth's surface is  $9.8 \text{ ms}^{-2}$ . The altitude above its surface at which the acceleration due to gravity decreases to  $4.9 \text{ ms}^{-2}$ , is close to : (Radius of earth =  $6.4 \times 10^6 \text{ m}$ )

- (1)  $1.6 \times 10^6 \text{ m}$                       (2)  $6.4 \times 10^6 \text{ m}$   
 (3)  $9.0 \times 10^6 \text{ m}$                       (4)  $2.6 \times 10^6 \text{ m}$

**Official Ans. by NTA (4)**

**Sol.**  $\frac{GM}{(R+h)^2} = \frac{GM}{2R^2}$

$$R + h = \sqrt{2}R$$

$$h = (\sqrt{2} - 1)R$$

$$\approx 2.6 \times 10^6 \text{ m}$$

28. Given below in the the left column are different modes of communication using the kinds of waves given the right column.

A.	Optical Fibre communication	P.	Ultrasound
B.	Radar	Q.	Infrared Light
C.	Sonar	R.	Microwaves
D.	Mobile Phones	S.	Radio Waves

(1) A-S, B-Q, C-R, D-P

(2) A-R, B-P, C-S, D-Q

(3) A-Q, B-S, C-R, D-P

(4) A-Q, B-S, C-P, D-R

**Official Ans. by NTA (4)**

**Sol.** Conceptual

29. The ratio of surface tensions of mercury and water is given to be 7.5 while the ratio of their densities is 13.6. Their contact angles, with glass, are close to  $135^\circ$  and  $0^\circ$ , respectively. It is observed that mercury gets depressed by an amount  $h$  in a capillary tube of radius  $r_1$ , while water rises by the same amount  $h$  in a capillary tube of radius  $r_2$ . The ratio,  $(r_1/r_2)$ , is then close to :

(1)  $2/3$

(2)  $3/5$

(3)  $2/5$

(4)  $4/5$

**Official Ans. by NTA (3)**

**Sol.**  $h = \frac{2S_1 \cos \theta_1}{r_1 \rho_1 g}$

$$h = \frac{2S_2 \cos \theta_2}{r_2 \rho_2 g}$$

$$\Rightarrow \frac{r_1}{r_2} = \frac{2}{5}$$



30. Two particles, of masses  $M$  and  $2M$ , moving, as shown, with speeds of  $10\text{ m/s}$  and  $5\text{ m/s}$ , collide elastically at the origin. After the collision, they move along the indicated directions with speeds  $v_1$  and  $v_2$ , respectively. The values of  $v_1$  and  $v_2$  are nearly :

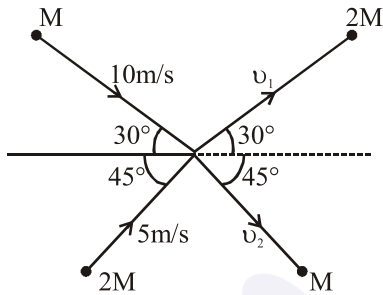

- (1)  $3.2\text{ m/s}$  and  $6.3\text{ m/s}$
- (2)  $3.2\text{ m/s}$  and  $12.6\text{ m/s}$
- (3)  $6.5\text{ m/s}$  and  $6.3\text{ m/s}$
- (4)  $6.5\text{ m/s}$  and  $3.2\text{ m/s}$

Official Ans. by NTA (3)

Sol.  $M \times 10 \cos 30^\circ + 2M \times 5 \cos 45^\circ$   
 $= 2M \times v_1 \cos 30^\circ + M v_2 \cos 45^\circ$

$$5\sqrt{3} + 5\sqrt{2} = 2v_1 \frac{\sqrt{3}}{2} + \frac{v_2}{\sqrt{2}}$$

$$10 \times M \sin 30^\circ - 2M \times 5 \sin 45^\circ$$

$$= M v_2 \sin 45^\circ - 2M v_1 \sin 30^\circ$$

$$5 - 5\sqrt{2} = \frac{v_2}{\sqrt{2}} - v_1$$

Solving  $v_1 = \frac{17.5}{2.7} \approx 6.5\text{ m/s}$

$$v_2 \approx 6.3\text{ m/s}$$