

FINAL JEE-MAIN EXAMINATION – AUGUST, 2021

(Held On Tuesday 31st August, 2021)

TIME : 9 : 00 AM to 12 : 00 NOON

PHYSICS

TEST PAPER WITH SOLUTION

SECTION-A

1. A helicopter is flying horizontally with a speed 'v' at an altitude 'h' has to drop a food packet for a man on the ground. What is the distance of helicopter from the man when the food packet is dropped?

- (1) $\sqrt{\frac{2ghv^2 + 1}{h^2}}$ (2) $\sqrt{2ghv^2 + h^2}$
 (3) $\sqrt{\frac{2v^2h}{g} + h^2}$ (4) $\sqrt{\frac{2gh}{v^2} + h^2}$

Official Ans. by NTA (3)

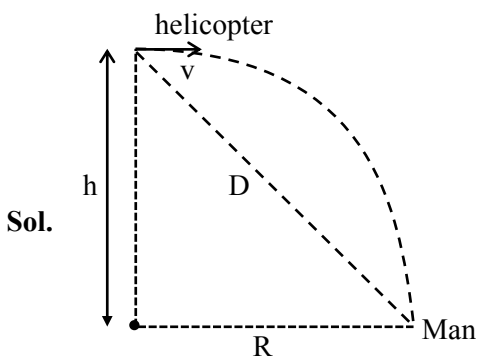

$$R = \sqrt{\frac{2h}{g}} \cdot v$$

$$D = \sqrt{R^2 + h^2} = \sqrt{\left(\sqrt{\frac{2h}{g}} \cdot v\right)^2 + h^2}$$

$$D = \sqrt{\frac{2hv^2}{g} + h^2}$$

Option (3) is correct

2. In the following logic circuit the sequence of the inputs A, B are (0, 0), (0,1), (1, 0) and (1, 1). The output Y for this sequence will be :

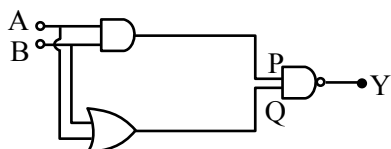

- (1) 1, 0, 1, 0 (2) 0, 1, 0, 1
 (3) 1, 1, 1, 0 (4) 0, 0, 1, 1

Official Ans. by NTA (3)

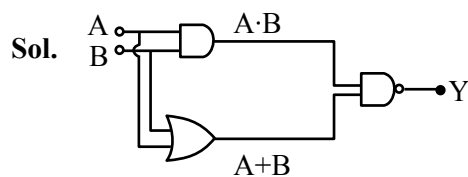

$$Y = \overline{(A \cdot B)} \cdot \overline{(A + B)}$$

$$Y_{(0,0)} = 1$$

$$Y_{(0,1)} = 1$$

$$Y_{(1,0)} = 1$$

$$Y_{(1,1)} = 0$$

Option (3) is correct

3. Two particles A and B having charges $20 \mu\text{C}$ and $-5 \mu\text{C}$ respectively are held fixed with a separation of 5 cm. At what position a third charged particle should be placed so that it does not experience a net electric force?

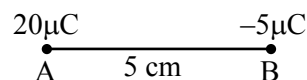

- (1) At 5 cm from $20 \mu\text{C}$ on the left side of system
 (2) At 5 cm from $-5 \mu\text{C}$ on the right side
 (3) At 1.25 cm from $-5 \mu\text{C}$ between two charges
 (4) At midpoint between two charges

Official Ans. by NTA (2)

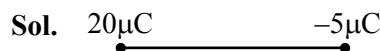

Null point is possible only right side of $-5 \mu\text{C}$

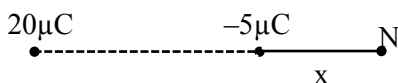

$$E_N = +\frac{k(-5\mu\text{C})}{x^2} + \frac{k(20\mu\text{C})}{(5+x)^2} = 0$$

$$x = 5 \text{ cm}$$

\therefore option (2) is correct

4. A reversible engine has an efficiency of $\frac{1}{4}$. If the temperature of the sink is reduced by 58°C , its efficiency becomes double. Calculate the temperature of the sink :

- (1) 174°C (2) 280°C
 (3) 180.4°C (4) 382°C

Official Ans. by NTA (1)

Official Ans. by ALLEN (Bonus)

Sol. $T_2 =$ sink temperature

$$\eta = 1 - \frac{T_2}{T_1}$$

$$\frac{1}{4} = 1 - \frac{T_2}{T_1}$$

$$\frac{T_2}{T_1} = \frac{3}{4} \dots (i)$$

$$\frac{1}{2} = 1 - \frac{T_2 - 58}{T_1}$$

$$\frac{T_2 - 58}{T_1} = \frac{1}{2}$$

$$\frac{3}{4} = \frac{58}{T_1} + \frac{1}{2}$$

$$\frac{1}{4} = \frac{58}{T_1} \Rightarrow T_1 = 232$$

$$T_2 = \frac{3}{4} \times 232$$

$$T_2 = 174 \text{ K}$$

5. An object is placed at the focus of concave lens having focal length f . What is the magnification and distance of the image from the optical centre of the lens?

- (1) 1, ∞ (2) Very high, ∞
 (3) $\frac{1}{2}, \frac{f}{2}$ (4) $\frac{1}{4}, \frac{f}{4}$

Official Ans. by NTA (3)

Sol.

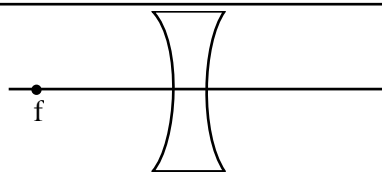

$$U = -f$$

$$\frac{1}{V} - \frac{1}{U} = \frac{1}{-f} \Rightarrow \frac{1}{V} = -\frac{2}{f}$$

$$V = \frac{-f}{2}$$

$$m = \frac{V}{U} = \frac{1}{2}$$

$$\text{distance} = \frac{f}{2}$$

Option (3)

6. A sample of a radioactive nucleus A disintegrates to another radioactive nucleus B, which in turn disintegrates to some other stable nucleus C. Plot of a graph showing the variation of number of atoms of nucleus B versus time is :

(Assume that at $t = 0$, there are no B atoms in the sample)

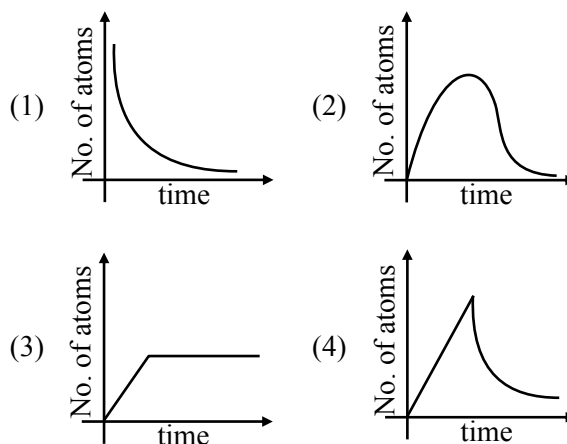

Official Ans. by NTA (2)

Sol. $A \longrightarrow B \longrightarrow C$ (stable)

Initially no. of atoms of B = 0 after $t = 0$, no. of atoms of B will start increasing & reaches maximum value when rate of decay of B = rate of formation of B.

After that maximum value, no. of atoms will start decreasing as growth & decay both are exponential functions, so best possible graph is (2)

Option (2)

7. A coil having N turns is wound tightly in the form of a spiral with inner and outer radii 'a' and 'b' respectively. Find the magnetic field at centre, when a current I passes through coil :

- (1) $\frac{\mu_0 IN}{2(b-a)} \log_e \left(\frac{b}{a} \right)$ (2) $\frac{\mu_0 I}{8} \left[\frac{a+b}{a-b} \right]$
 (3) $\frac{\mu_0 I}{4(a-b)} \left[\frac{1}{a} - \frac{1}{b} \right]$ (4) $\frac{\mu_0 I}{8} \left(\frac{a-b}{a+b} \right)$

Official Ans. by NTA (1)

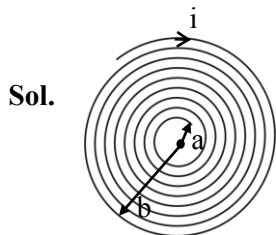

No. of turns in dx width = $\frac{N}{b-a} dx$

$$\int dB = \int_a^b \left(\frac{N}{b-a} \right) dx \frac{\mu_0 i}{2x}$$

$$B = \frac{N\mu_0 i}{2(b-a)} \ell n \left(\frac{b}{a} \right)$$

Option (1)

8. A body of mass M moving at speed V_0 collides elastically with a mass 'm' at rest. After the collision, the two masses move at angles θ_1 and θ_2 with respect to the initial direction of motion of the body of mass M. The largest possible value of the ratio M/m, for which the angles θ_1 and θ_2 will be equal, is :

- (1) 4 (2) 1 (3) 3 (4) 2

Official Ans. by NTA (3)

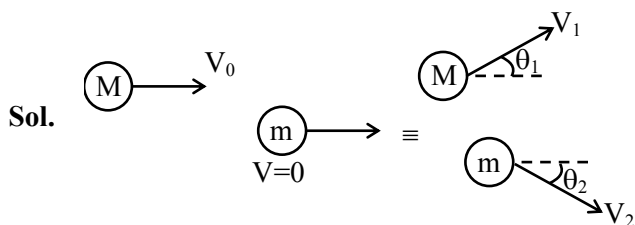

given $\theta_1 = \theta_2 = \theta$

from momentum conservation

in x-direction $MV_0 = MV_1 \cos \theta + mV_2 \cos \theta$

in y-direction $0 = MV_1 \sin \theta - mV_2 \sin \theta$

Solving above equations

$$V_2 = \frac{MV_1}{m}, V_0 = 2V_1 \cos \theta$$

From energy conservation

$$\frac{1}{2} MV_0^2 = \frac{1}{2} MV_1^2 + \frac{1}{2} mV_2^2$$

Substituting value of V_2 & V_0 , we will get

$$\frac{M}{m} + 1 = 4 \cos^2 \theta \leq 4$$

$$\frac{M}{m} \leq 3$$

Option (3)

9. The masses and radii of the earth and moon are (M_1, R_1) and (M_2, R_2) respectively. Their centres are at a distance 'r' apart. Find the minimum escape velocity for a particle of mass 'm' to be projected from the middle of these two masses:

(1) $V = \frac{1}{2} \sqrt{\frac{4G(M_1 + M_2)}{r}}$

(2) $V = \sqrt{\frac{4G(M_1 + M_2)}{r}}$

(3) $V = \frac{1}{2} \sqrt{\frac{2G(M_1 + M_2)}{r}}$

(4) $V = \frac{\sqrt{2G(M_1 + M_2)}}{r}$

Official Ans. by NTA (2)

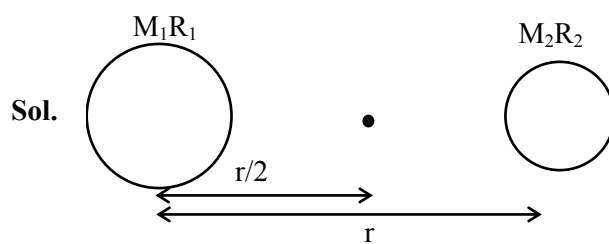

$$\frac{1}{2} mV^2 - \frac{GM_1 m}{r/2} - \frac{GM_2 m}{r/2} = 0$$

$$\frac{1}{2} mV^2 = \frac{2Gm}{r} (M_1 + M_2)$$

$$V = \sqrt{\frac{4G(M_1 + M_2)}{r}}$$

Option (2)

10. A small square loop of side 'a' and one turn is placed inside a larger square loop of side b and one turn ($b \gg a$). The two loops are coplanar with their centres coinciding. If a current I is passed in the square loop of side 'b', then the coefficient of mutual inductance between the two loops is :

- (1) $\frac{\mu_0}{4\pi} 8\sqrt{2} \frac{a^2}{b}$ (2) $\frac{\mu_0}{4\pi} \frac{8\sqrt{2}}{a}$
 (3) $\frac{\mu_0}{4\pi} 8\sqrt{2} \frac{b^2}{a}$ (4) $\frac{\mu_0}{4\pi} \frac{8\sqrt{2}}{b}$

Official Ans. by NTA (1)

Sol.

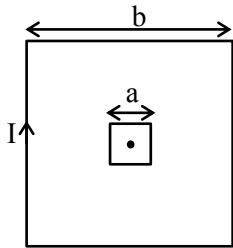

$$B = \left[\frac{\mu_0 I}{4\pi b/2} \times 2 \sin 45^\circ \right] \times 4$$

$$\phi = 2\sqrt{2} \frac{\mu_0 I}{\pi b} \times a^2$$

$$\therefore M = \frac{\phi}{I} = \frac{2\sqrt{2} \mu_0 a^2}{\pi b} = \frac{\mu_0}{4\pi} 8\sqrt{2} \frac{a^2}{b}$$

Option (1)

11. Choose the correct waveform that can represent the voltage across R of the following circuit, assuming the diode is ideal one:

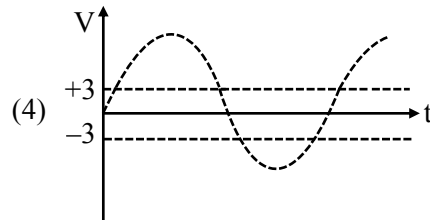
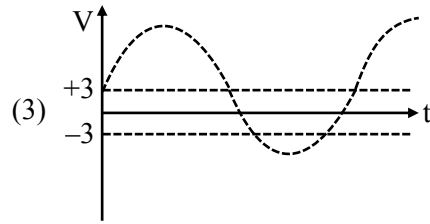
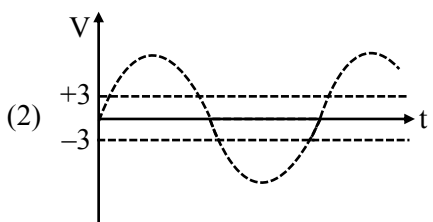
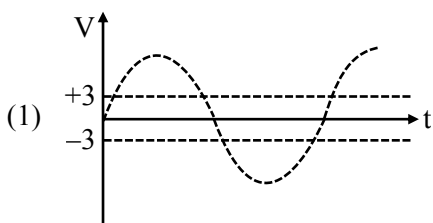
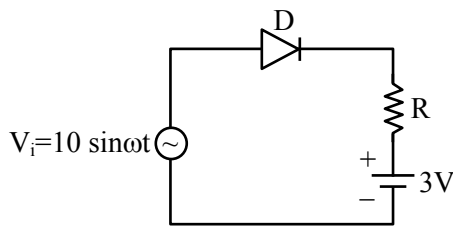

Official Ans. by NTA (3)

Official Ans. by ALLEN (1)

Sol. When $V_i > 3$ volt, $V_R > 0$

Because diode will be in forward biased state

When $V_i \leq 3$ volt ; $V_R = 0$

Because diode will be in reverse biased state.

12. A uniform heavy rod of weight 10 kg ms^{-2} , cross-sectional area 100 cm^2 and length 20 cm is hanging from a fixed support. Young modulus of the material of the rod is $2 \times 10^{11} \text{ Nm}^{-2}$. Neglecting the lateral contraction, find the elongation of rod due to its own weight.

- (1) $2 \times 10^{-9} \text{ m}$ (2) $5 \times 10^{-8} \text{ m}$
 (3) $4 \times 10^{-8} \text{ m}$ (4) $5 \times 10^{-10} \text{ m}$

Official Ans. by NTA (4)

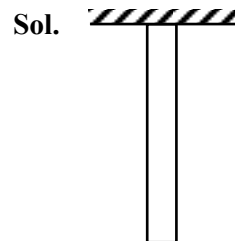

We know,

$$\Delta \ell = \frac{WL}{2AY}$$

$$\Delta \ell = \frac{10 \times 1}{2 \times 5} \times 100 \times 10^{-4} \times 2 \times 10^{11}$$

$$\Delta \ell = \frac{1}{2} \times 10^{-9} = 5 \times 10^{-10} \text{ m}$$

Option (4)

13. Two plane mirrors M_1 and M_2 are at right angle to each other shown. A point source 'P' is placed at 'a' and '2a' meter away from M_1 and M_2 respectively. The shortest distance between the images thus formed is : (Take $\sqrt{5} = 2.3$)

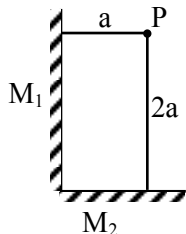

- (1) 3a (2) 4.6 a
 (3) 2.3 a (4) $2\sqrt{10} a$

Official Ans. by NTA (2)

Sol.

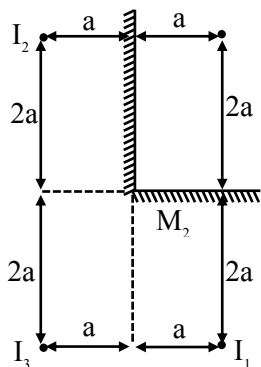

Shortest distance is 2a between I_1 & I_3

But answer given is for I_1 & I_2

$$\sqrt{(4a)^2 + (2a)^2}$$

$$a\sqrt{20}$$

$$4.47 a$$

Option (2)

14. Match List-I with List-II.

List-I

- (a) Torque
 (b) Impulse
 (c) Tension
 (d) Surface Tension

List-II

- (i) MLT^{-1}
 (ii) MT^{-2}
 (iii) ML^2T^{-2}
 (iv) MLT^{-2}

Choose the **most appropriate** answer from the option given below :

- (1) (a)–(iii), (b)–(i), (c)–(iv), (d)–(ii)
 (2) (a)–(ii), (b)–(i), (c)–(iv), (d)–(iii)
 (3) (a)–(i), (b)–(iii), (c)–(iv), (d)–(ii)
 (4) (a)–(iii), (b)–(iv), (c)–(i), (d)–(ii)

Official Ans. by NTA (1)

Sol. torque $\tau \rightarrow ML^2T^{-2}$ (III)

Impulse $I \Rightarrow MLT^{-1}$ (I)

Tension force $\Rightarrow MLT^{-2}$ (IV)

Surface tension $\Rightarrow MT^{-2}$ (II)

Option (1)

15. For an ideal gas the instantaneous change in pressure 'p' with volume 'v' is given by the

equation $\frac{dp}{dv} = -ap$. If $p = p_0$ at $v = 0$ is the given

boundary condition, then the maximum temperature one mole of gas can attain is :

(Here R is the gas constant)

(1) $\frac{p_0}{aeR}$ (2) $\frac{ap_0}{eR}$

(3) infinity (4) $0^\circ C$

Official Ans. by NTA (1)

Sol. $\int_{p_0}^p \frac{dp}{p} = -a \int_0^v dv$

$$\ln\left(\frac{p}{p_0}\right) = -av$$

$$p = p_0 e^{-av}$$

For temperature maximum p-v product should be maximum

$$T = \frac{pv}{nR} = \frac{p_0 v e^{-av}}{R}$$

$$\frac{dT}{dv} = 0 \Rightarrow \frac{p_0}{R} \{e^{-av} + v e^{-av} (-a)\}$$

$$\frac{p_0 e^{-av}}{R} \{1 - av\} = 0$$

$$v = \frac{1}{a}, \infty$$

$$T = \frac{p_0 \cdot 1}{Rae} = \frac{p_0}{Rae}$$

at $v = \infty$

$$T = 0$$

Option (1)

16. Which of the following equations is dimensionally incorrect ?

Where t = time, h = height, s = surface tension, θ = angle, ρ = density, a, r = radius, g = acceleration due to gravity, v = volume, p = pressure, W = work done, Γ = torque, ϵ = permittivity, E = electric field, J = current density, L = length.

$$(1) v = \frac{\pi p a^4}{8 \eta L} \quad (2) h = \frac{2s \cos \theta}{\rho r g}$$

$$(3) J = \epsilon \frac{\partial E}{\partial t} \quad (4) W = \Gamma \theta$$

Official Ans. by NTA (1)

Sol. (i) $\frac{\pi p a^4}{8 \eta L} = \frac{dv}{dt}$ = Volumetric flow rate

(poiseuille's law)

$$(ii) h \rho g = \frac{2s}{r} \cos \theta$$

$$(iii) \text{RHS} \Rightarrow \epsilon \times \frac{1}{4\pi\epsilon_0} \frac{a}{r^2} \times \frac{1}{\epsilon} = \frac{q}{t} \times \frac{1}{r^2}$$

$$= \frac{I}{L^2} = \text{IL}^{-2}$$

LHS

$$T = \frac{I}{A} = \text{IL}^{-2}$$

$$(iv) W = \tau \theta$$

Option (1)

17. Angular momentum of a single particle moving with constant speed along circular path :

(1) changes in magnitude but remains same in the direction

(2) remains same in magnitude and direction

(3) remains same in magnitude but changes in the direction

(4) is zero

Official Ans. by NTA (2)

Sol.

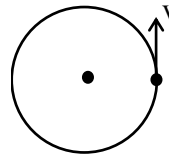

$$|\vec{L}| = mvr$$

And direction will be upward & remain constant

Option (2)

18. In an ac circuit, an inductor, a capacitor and a resistor are connected in series with $X_L = R = X_C$.

Impedance of this circuit is :

$$(1) 2R^2 \quad (2) \text{Zero}$$

$$(3) R \quad (4) R\sqrt{2}$$

Official Ans. by NTA (3)

Sol. $Z = \sqrt{(X_L - X_C)^2 + R^2} = R \because X_L = X_C$

Option (3)

19. A moving proton and electron have the same de-Broglie wavelength. If K and P denote the K.E. and momentum respectively. Then choose the correct option :

$$(1) K_p < K_e \text{ and } P_p = P_e$$

$$(2) K_p = K_e \text{ and } P_p = P_e$$

$$(3) K_p < K_e \text{ and } P_p < P_e$$

$$(4) K_p > K_e \text{ and } P_p = P_e$$

Official Ans. by NTA (1)

Sol. $\lambda_p = \frac{h}{P_p} \quad \lambda_e = \frac{h}{P_e}$

$$\because \lambda_p = \lambda_e$$

$$\Rightarrow P_p = P_e$$

$$(K)_p = \frac{P_p^2}{2m_p}$$

$$(K)_e = \frac{P_e^2}{2m_e}$$

$$K_p < K_e \text{ as } m_p > m_e$$

Option (1)

20. Consider a galvanometer shunted with 5Ω resistance and 2% of current passes through it.

What is the resistance of the given galvanometer ?

- (1) 300Ω (2) 344Ω
 (3) 245Ω (4) 226Ω

Official Ans. by NTA (3)

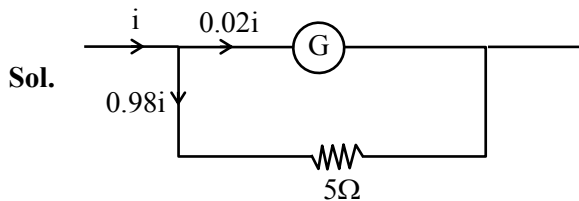

$$0.02i R_g = 0.98i \times 5$$

$$R_g = 245\Omega$$

Option (3)

SECTION-B

1. When a rubber ball is taken to a depth of _____ m in deep sea, its volume decreases by 0.5%.

(The bulk modulus of rubber = $9.8 \times 10^8 \text{ Nm}^{-2}$

Density of sea water = 10^3 kgm^{-3}

$$g = 9.8 \text{ m/s}^2$$

Official Ans. by NTA (500)

Sol.

$$B = -\frac{\Delta P}{\left(\frac{\Delta V}{V}\right)} = -\frac{\rho gh}{\left(\frac{\Delta V}{V}\right)}$$

$$-\frac{B \frac{\Delta V}{V}}{\rho g} = h$$

$$\frac{9.8 \times 10^8 \times 0.5}{100 \times 10^3 \times 9.8} = h$$

$$h = 500$$

2. A particle of mass 1 kg is hanging from a spring of force constant 100 Nm^{-1} . The mass is pulled slightly downward and released so that it executes free simple harmonic motion with time period T. The time when the kinetic energy and potential energy of the system will become equal, is $\frac{T}{x}$. The value of x is _____.

Official Ans. by NTA (8)

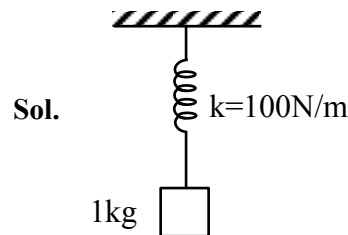

$$KE = PE$$

$$y = \frac{A}{\sqrt{2}} = A \sin \omega t$$

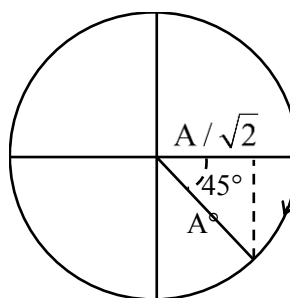

$$t = \frac{T}{8} = \frac{T}{x}$$

$$x = 8$$

3. If the sum of the heights of transmitting and receiving antennas in the line of sight of communication is fixed at 160 m, then the maximum range of LOS communication is _____ km.

(Take radius of Earth = 6400 km)

Official Ans. by NTA (64)

Sol. $h_T = h_R = 160 \dots (i)$

$$d = \sqrt{2Rh_T} + \sqrt{2Rh_R}$$

$$d = \sqrt{2R} [\sqrt{h_T} + \sqrt{h_R}]$$

$$d = \sqrt{2R} [\sqrt{x} + \sqrt{160-x}]$$

$$\frac{d(d)}{dx} = 0$$

$$\frac{1}{2\sqrt{x}} + \frac{1(-1)}{2\sqrt{160-x}} = 0$$

$$\frac{1}{\sqrt{x}} = \frac{1}{\sqrt{160-x}}$$

$$x = 80 \text{ m}$$

$$d_{\max} = \sqrt{2 \times 6400} \left[\sqrt{\frac{80}{1000}} + \sqrt{\frac{20}{1000}} \right]$$

$$= \frac{80\sqrt{2} \times 2\sqrt{80}}{10\sqrt{10}}$$

$$= 8 \times 2 \times \sqrt{2} \times 2\sqrt{2} = 64 \text{ km}$$

4. A square shaped wire with resistance of each side 3Ω is bent to form a complete circle. The resistance between two diametrically opposite points of the circle in unit of Ω will be _____.

Official Ans. by NTA (3)

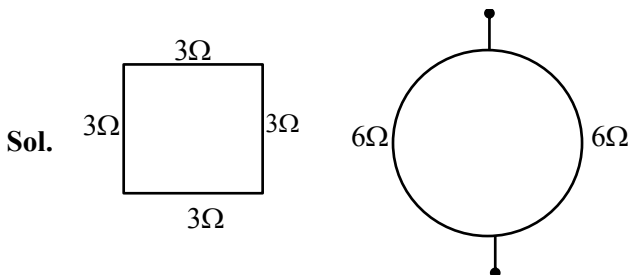

$$R_{\text{eq}} = 3\Omega$$

5. A wire having a linear mass density $9.0 \times 10^{-4} \text{ kg/m}$ is stretched between two rigid supports with a tension of 900 N. The wire resonates at a frequency of 500 Hz. The next higher frequency at which the same wire resonates is 550 Hz. The length of the wire is _____ m.

Official Ans. by NTA (10)

Sol. $\mu = 9.0 \times 10^{-4} \frac{\text{kg}}{\text{m}}$

$$T = 900 \text{ N}$$

$$V = \sqrt{\frac{T}{\mu}} = \sqrt{\frac{900}{9 \times 10^{-4}}} = 1000 \text{ m/s}$$

$$f_1 = 500 \text{ Hz}$$

$$f = 550$$

$$\frac{nV}{2\ell} = 500 \dots (i)$$

$$\frac{(n+1)V}{2\ell} = 500 \dots (ii)$$

$$(ii) - (i) \quad \frac{V}{2\ell} = 50$$

$$\ell = \frac{1000}{2 \times 50} = 10$$

6. The voltage drop across 15Ω resistance in the given figure will be _____ V.

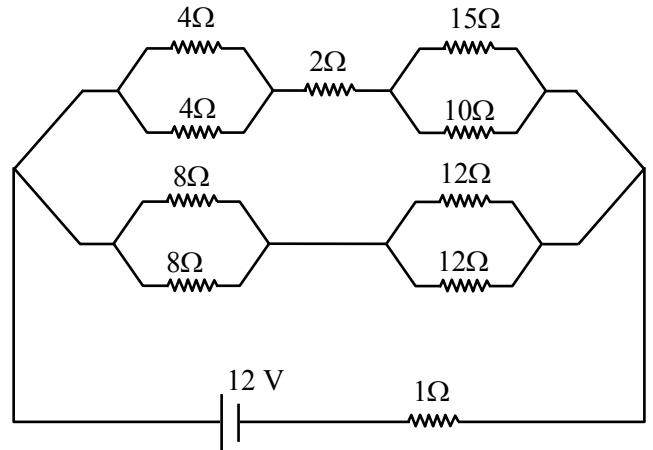

Official Ans. by NTA (6)

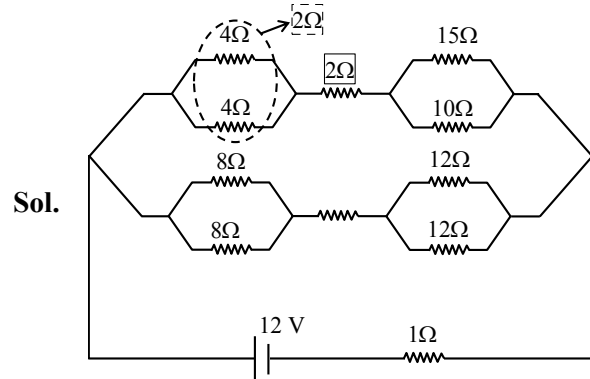

⇒ effective circuit diagram will be

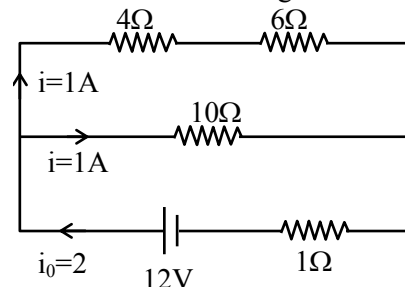

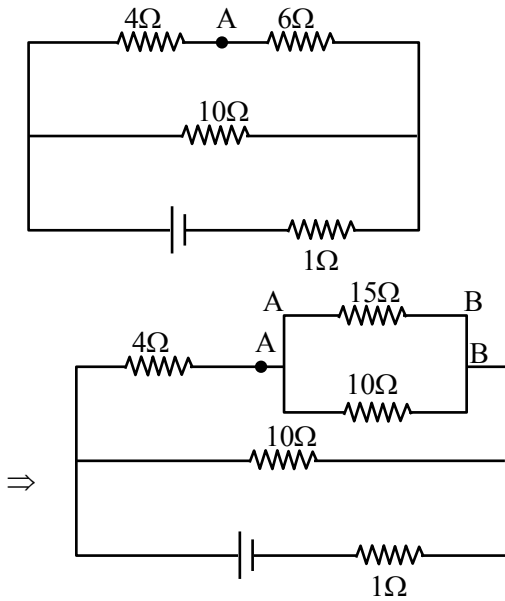

Point drop across $6\Omega = 1 \times 6 = 6 = V_{AB}$
 \Rightarrow Hence point drop across $15\Omega = 6 \text{ volt} = V_{AB}$

7. A block moving horizontally on a smooth surface with a speed of 40 ms^{-1} splits into two equal parts. If one of the parts moves at 60 ms^{-1} in the same direction, then the fractional change in the kinetic energy will be $x : 4$ where $x =$ _____.

Official Ans. by NTA (1)

Sol.

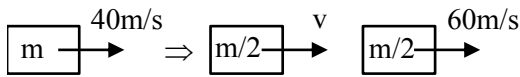

$$P_i = P_f$$

$$m \times 40 = \frac{m}{2} \times v + \frac{m}{2} \times 60$$

$$40 = \frac{v}{2} + 30$$

$$\Rightarrow v = 20$$

$$(K.E.)_i = \frac{1}{2} m \times (40)^2 = 800m$$

$$(K.E.)_f = \frac{1}{2} \frac{m}{2} \cdot (20)^2 + \frac{1}{2} \cdot \frac{m}{2} \cdot (60)^2 = 1000m$$

$$|\Delta K.E.| = |1000m - 800m| = 200m$$

$$\frac{\Delta K.E.}{(K.E.)_i} = \frac{200m}{800m} = \frac{1}{4} = \frac{x}{4}$$

$$x = 1$$

8. The electric field in an electromagnetic wave is given by $E = (50 \text{ NC}^{-1}) \sin \omega (t - x/c)$

The energy contained in a cylinder of volume V is $5.5 \times 10^{-12} \text{ J}$. The value of V is _____ cm^3 .

(given $\epsilon_0 = 8.8 \times 10^{-12} \text{ C}^2 \text{ N}^{-1} \text{ m}^{-2}$)

Official Ans. by NTA (500)

Sol. $E = 50 \sin \left(\omega t - \frac{\omega}{c} \cdot x \right)$

$$\text{Energy density} = \frac{1}{2} \epsilon_0 E^2$$

$$\text{Energy for volume } V = \frac{1}{2} \epsilon_0 E_0^2 \cdot V = 5.5 \times 10^{-12}$$

$$\frac{1}{2} 8.8 \times 10^{-12} \times 2500V = 5.5 \times 10^{-12}$$

$$V = \frac{5.5 \times 2}{2500 \times 8.8} = .0005 \text{ m}^3$$

$$= .0005 \times 10^6 \text{ (c.m)}^3$$

$$= 500 \text{ (c.m)}^3$$

9. A capacitor of $50 \mu\text{F}$ is connected in a circuit as shown in figure. The charge on the upper plate of the capacitor is _____ μC .

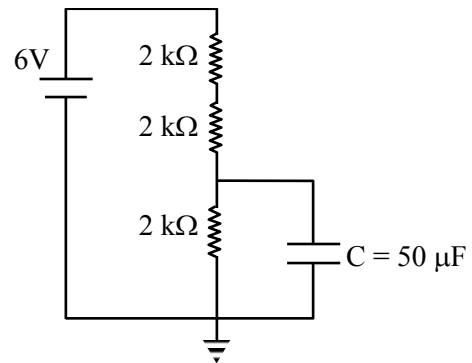

Official Ans. by NTA (100)

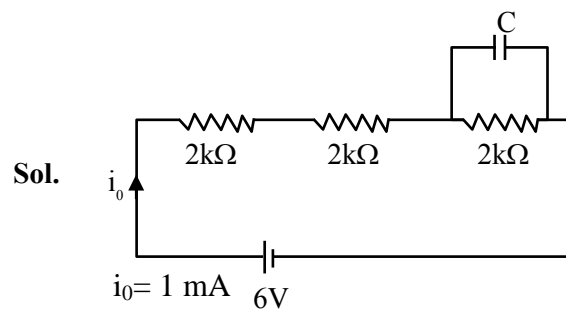

Sol.

Pot. Diff. across each resistor = 2V

$$q = CV$$

$$= 50 \times 10^{-6} \times 2 = 100 \times 10^{-6} = 100 \mu\text{C}$$

10. A car is moving on a plane inclined at 30° to the horizontal with an acceleration of 10 ms^{-2} parallel to the plane upward. A bob is suspended by a string from the roof of the car. The angle in degrees which the string makes with the vertical is _____. (Take $g = 10 \text{ ms}^{-2}$)

Official Ans. by NTA (30)

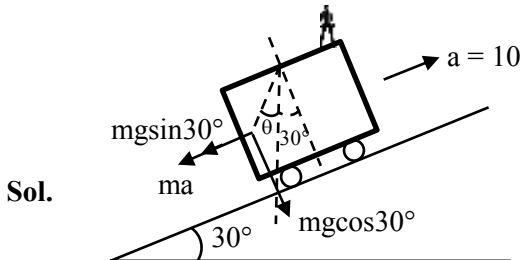

$$\tan(30 + \theta) = \frac{mg \sin 30^\circ + ma}{mg \cos 30^\circ}$$

$$\tan(30 + \theta) = \frac{5 + 10}{5\sqrt{3}} = \frac{1 + 2}{\sqrt{3}}$$

$$\frac{\tan \theta + \frac{1}{\sqrt{3}}}{1 - \frac{1}{\sqrt{3}} \tan \theta} = \sqrt{3}$$

$$\sqrt{3} \tan \theta + 1 = 3 - \sqrt{3} \tan \theta$$

$$2\sqrt{3} \tan \theta = 2$$

$$\tan \theta = \frac{1}{\sqrt{3}}$$

$$\theta = 30^\circ$$