

FINAL JEE-MAIN EXAMINATION – AUGUST, 2021

(Held On Thursday 26th August, 2021)

TIME : 9 : 00 AM to 12 : 00 NOON

PHYSICS

TEST PAPER WITH SOLUTION

SECTION-A

1. The fractional change in the magnetic field intensity at a distance 'r' from centre on the axis of current carrying coil of radius 'a' to the magnetic field intensity at the centre of the same coil is :
(Take $r < a$)

- (1) $\frac{3 a^2}{2 r^2}$ (2) $\frac{2 a^2}{3 r^2}$
(3) $\frac{2 r^2}{3 a^2}$ (4) $\frac{3 r^2}{2 a^2}$

Official Ans. by NTA (4)

Sol. $B_{\text{axis}} = \frac{\mu_0 i R^2}{2(R^2 + x^2)^{3/2}}$

$B_{\text{centre}} = \frac{\mu_0 i}{2R}$

$\therefore B_{\text{centre}} = \frac{\mu_0 i}{2a}$

$\therefore B_{\text{axis}} = \frac{\mu_0 i a^2}{2(a^2 + r^2)^{3/2}}$

\therefore fractional change in magnetic field =

$$\frac{\frac{\mu_0 i}{2a} - \frac{\mu_0 i a^2}{2(a^2 + r^2)^{3/2}}}{\frac{\mu_0 i}{2a}} = 1 - \frac{1}{\left[1 + \left(\frac{r^2}{a^2}\right)\right]^{3/2}}$$

$\approx 1 - \left[1 - \frac{3 r^2}{2 a^2}\right] = \frac{3 r^2}{2 a^2}$

Note : $\left(1 + \frac{r^2}{a^2}\right)^{-3/2} \approx \left(1 - \frac{3 r^2}{2 a^2}\right)$

[True only if $r \ll a$]

Hence option (4) is the most suitable option

2. The magnitude of vectors \vec{OA} , \vec{OB} and \vec{OC} in the given figure are equal. The direction of $\vec{OA} + \vec{OB} - \vec{OC}$ with x-axis will be :-

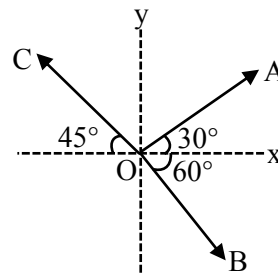

- (1) $\tan^{-1} \frac{(1 - \sqrt{3} - \sqrt{2})}{(1 + \sqrt{3} + \sqrt{2})}$
(2) $\tan^{-1} \frac{(\sqrt{3} - 1 + \sqrt{2})}{(1 + \sqrt{3} - \sqrt{2})}$
(3) $\tan^{-1} \frac{(\sqrt{3} - 1 + \sqrt{2})}{(1 - \sqrt{3} + \sqrt{2})}$
(4) $\tan^{-1} \frac{(1 + \sqrt{3} - \sqrt{2})}{(1 - \sqrt{3} - \sqrt{2})}$

Official Ans. by NTA (1)

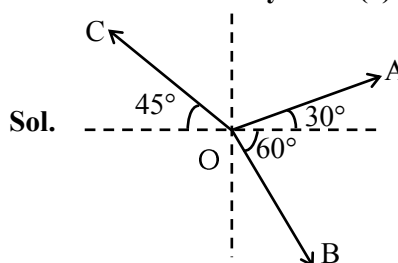

Let magnitude be equal to λ .

$\vec{OA} = \lambda [\cos 30^\circ \hat{i} + \sin 30^\circ \hat{j}] = \lambda \left[\frac{\sqrt{3}}{2} \hat{i} + \frac{1}{2} \hat{j} \right]$

$\vec{OB} = \lambda [\cos 60^\circ \hat{i} - \sin 60^\circ \hat{j}] = \lambda \left[\frac{1}{2} \hat{i} - \frac{\sqrt{3}}{2} \hat{j} \right]$

$\vec{OC} = \lambda [\cos 45^\circ (-\hat{i}) + \sin 45^\circ \hat{j}] = \lambda \left[-\frac{1}{\sqrt{2}} \hat{i} + \frac{1}{\sqrt{2}} \hat{j} \right]$

$\therefore \vec{OA} + \vec{OB} - \vec{OC}$

$= \lambda \left[\left(\frac{\sqrt{3} + 1}{2} + \frac{1}{\sqrt{2}} \right) \hat{i} + \left(\frac{1}{2} - \frac{\sqrt{3}}{2} - \frac{1}{\sqrt{2}} \right) \hat{j} \right]$

∴ Angle with x-axis

$$\tan^{-1} \left[\frac{\frac{1}{2} - \frac{\sqrt{3}}{2} - \frac{1}{\sqrt{2}}}{\frac{\sqrt{3}}{2} + \frac{1}{2} + \frac{1}{\sqrt{2}}} \right] = \tan^{-1} \left[\frac{\sqrt{2} - \sqrt{6} - 2}{\sqrt{6} + \sqrt{2} + 2} \right]$$

$$= \tan^{-1} \left[\frac{1 - \sqrt{3} - \sqrt{2}}{\sqrt{3} + 1 + \sqrt{2}} \right]$$

Hence option (1)

3. Car B overtakes another car A at a relative speed of 40 ms^{-1} . How fast will the image of car B appear to move in the mirror of focal length 10 cm fitted in car A, when the car B is 1.9 m away from the car A?

- (1) 4 ms^{-1} (2) 0.2 ms^{-1}
 (3) 40 ms^{-1} (4) 0.1 ms^{-1}

Official Ans. by NTA (4)



Mirror used is convex mirror (rear-view mirror)

$$\therefore V_{I/m} = -m^2 V_{O/m}$$

Given,

$$V_{O/m} = 40 \text{ m/s}$$

$$m = \frac{f}{f - u} = \frac{10}{10 + 190} = \frac{10}{200}$$

$$\therefore V_{I/m} = -\frac{1}{400} \times 40 = -0.1 \text{ m/s}$$

∴ Car will appear to move with speed 0.1 m/s.

Hence option (4)

4. Inside a uniform spherical shell :

- (a) the gravitational field is zero
 (b) the gravitational potential is zero
 (c) the gravitational field is same everywhere
 (d) the gravitation potential is same everywhere
 (e) all of the above

Choose the most appropriate answer from the options given below :

- (1) (a), (c) and (d) only
 (2) (e) only
 (3) (a), (b) and (c) only
 (4) (b), (c) and (d) only

Official Ans. by NTA (1)

- Sol. Inside a spherical shell, gravitational field is zero and hence potential remains same everywhere
 Hence option (1)

5. Two narrow bores of diameter 5.0 mm and 8.0 mm are joined together to form a U-shaped tube open at both ends. If this U-tube contains water, what is the difference in the level of two limbs of the tube.
 [Take surface tension of water $T = 7.3 \times 10^{-2} \text{ Nm}^{-1}$, angle of contact = 0, $g = 10 \text{ ms}^{-2}$ and density of water = $1.0 \times 10^3 \text{ kg m}^{-3}$]

- (1) 3.62 mm (2) 2.19 mm
 (3) 5.34 mm (4) 4.97 mm

Official Ans. by NTA (2)

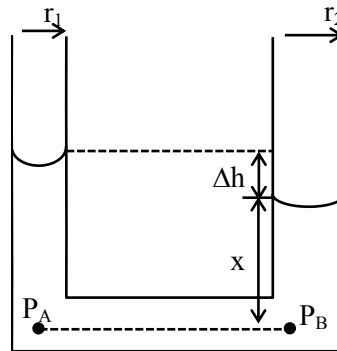

Sol.

We have $P_A = P_B$. [Points A & B at same horizontal level]

$$\therefore P_{\text{atm}} - \frac{2T}{r_1} + \rho g(x + \Delta h) = P_{\text{atm}} - \frac{2T}{r_2} + \rho g x$$

$$\therefore \rho g \Delta h = 2T \left[\frac{1}{r_1} - \frac{1}{r_2} \right]$$

$$= 2 \times 7.3 \times 10^{-2} \left[\frac{1}{2.5 \times 10^{-3}} - \frac{1}{4 \times 10^{-3}} \right]$$

$$\therefore \Delta h = \frac{2 \times 7.3 \times 10^{-2} \times 10^3}{10^3 \times 10} \left[\frac{1}{2.5} - \frac{1}{4} \right]$$

$$= 2.19 \times 10^{-3} \text{ m} = 2.19 \text{ mm}$$

Hence option (2)

6. An electric appliance supplies 6000 J/min heat to the system. If the system delivers a power of 90W. How long it would take to increase the internal energy by $2.5 \times 10^3 \text{ J}$?

- (1) $2.5 \times 10^2 \text{ s}$ (2) $4.1 \times 10^1 \text{ s}$
 (3) $2.4 \times 10^3 \text{ s}$ (4) $2.5 \times 10^1 \text{ s}$

Official Ans. by NTA (1)

Sol. $\Delta Q = \Delta U + \Delta W$

$$\frac{\Delta Q}{\Delta t} = \frac{\Delta U}{\Delta t} + \frac{\Delta W}{\Delta t}$$

$$\frac{6000 \text{ J}}{60 \text{ sec}} = \frac{2.5 \times 10^3}{\Delta t} + 90$$

$$\Delta t = 250 \text{ sec}$$

Option (1)

7. An inductor coil stores 64 J of magnetic field energy and dissipates energy at the rate of 640 W when a current of 8A is passed through it. If this coil is joined across an ideal battery, find the time constant of the circuit in seconds :

- (1) 0.4 (2) 0.8 (3) 0.125 (4) 0.2

Official Ans. by NTA (4)

Sol. $U = \frac{1}{2} Li^2 = 64 \Rightarrow L = 2$

$$i^2 R = 640$$

$$R = \frac{640}{(8)^2} = 10$$

$$\tau = \frac{L}{R} = \frac{1}{5} = 0.2$$

Option (4)

8. A series LCR circuit driven by 300 V at a frequency of 50 Hz contains a resistance $R = 3 \text{ k}\Omega$, an inductor of inductive reactance $X_L = 250 \pi \Omega$ and an unknown capacitor. The value of capacitance to maximize the average power should be : (Take $\pi^2 = 10$)

- (1) 4 μF (2) 25 μF (3) 400 μF (4) 40 μF

Official Ans. by NTA (1)

Sol. For maximum average power

$$X_L = X_C$$

$$250\pi = \frac{1}{2\pi(50)C}$$

$$C = 4 \times 10^{-6}$$

Option (1)

9. Identify the logic operation carried out by the given circuit :-

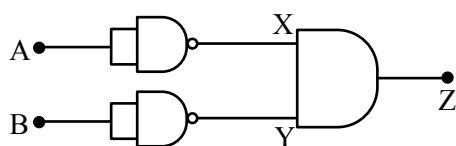

- (1) OR (2) AND (3) NOR (4) NAND

Official Ans. by NTA (3)

	A	B	X	Y	Z
	1	1	0	0	0
	1	0	0	1	0
	0	1	1	0	0
	0	0	1	1	1

Sol.

Option (3)

10. A particular hydrogen like ion emits radiation of frequency 2.92×10^{15} Hz when it makes transition from $n = 3$ to $n = 1$. The frequency in Hz of radiation emitted in transition from $n = 2$ to $n = 1$ will be :

- (1) 0.44×10^{15} (2) 6.57×10^{15}
 (3) 4.38×10^{15} (4) 2.46×10^{15}

Official Ans. by NTA (4)

Sol. $nf_1 = k \left(\frac{1}{1} - \frac{1}{3^2} \right)$

$$nf_2 = k \left(1 - \frac{1}{2^2} \right)$$

$$\frac{f_1}{f_2} = \frac{8/9}{3/4} \Rightarrow f_2 = 2.46 \times 10^{15}$$

Option (4)

11. In a photoelectric experiment ultraviolet light of wavelength 280 nm is used with lithium cathode having work function $\phi = 2.5 \text{ eV}$. If the wavelength of incident light is switched to 400 nm, find out the change in the stopping potential. ($h = 6.63 \times 10^{-34} \text{ Js}$, $c = 3 \times 10^8 \text{ ms}^{-1}$)

- (1) 1.3 V (2) 1.1 V (3) 1.9 V (4) 0.6 V

Official Ans. by NTA (1)

Sol. $KE_{\max} = eV_s = \frac{hc}{\lambda} - \phi$

$$\Rightarrow eV_{s_1} = \frac{1240}{280} - 2.5 = 1.93 \text{ eV}$$

$$\rightarrow V_{s_1} = 1.93 \text{ V} \dots (i)$$

$$\rightarrow eV_{s_2} = \frac{1240}{400} - 2.5 = 0.6 \text{ eV}$$

$$\Rightarrow V_{s_2} = 0.6 \text{ V} \dots (ii)$$

$$\Delta V = V_{s_1} - V_{s_2} = 1.93 - 0.6 = 1.33 \text{ V}$$

Option (1)

12. In the given figure, the emf of the cell is 2.2 V and if internal resistance is 0.6Ω . Calculate the power dissipated in the whole circuit :

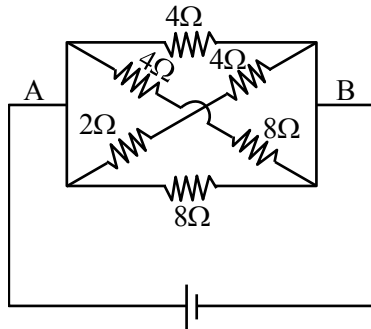

2.2 V, $r=0.6\Omega$

- (1) 1.32 W (2) 0.65 W
 (3) 2.2 W (4) 4.4 W

Official Ans. by NTA (3)

Sol.

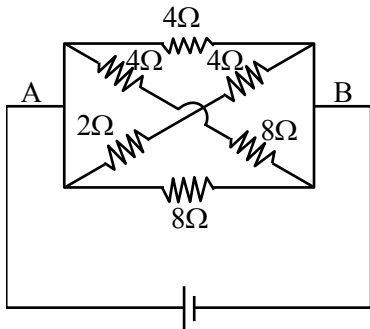

2.2 V, $r=0.6\Omega$

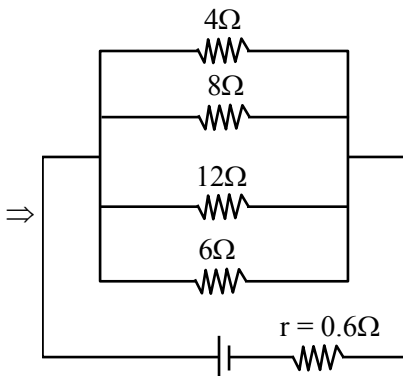

2.2 V

$$\frac{1}{R_{eq}} = \frac{1}{4} + \frac{1}{8} + \frac{1}{12} + \frac{1}{6} = \frac{6+3+2+4}{24} = \frac{15}{24}$$

$$R_{eq} = \frac{24}{15} = 1.6 \Rightarrow R_T = 1.6 + 0.6 = 2.2\Omega$$

$$P = \frac{V^2}{R_T} = \frac{(2.2)^2}{2.2} = 2.2\text{ W}$$

Option (3)

13. A solid metal sphere of radius R having charge q is enclosed inside the concentric spherical shell of inner radius a and outer radius b as shown in figure. The approximate variation electric field \vec{E} as a function of distance r from centre O is given by

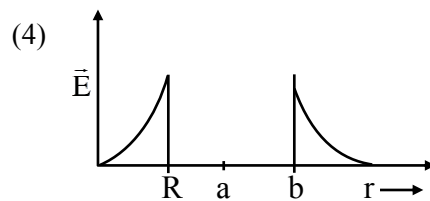
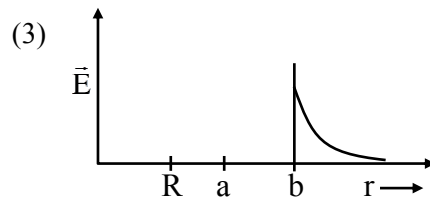
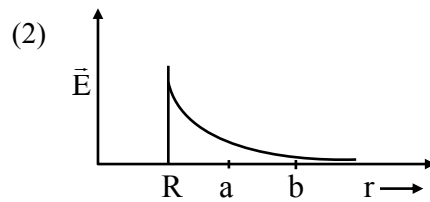
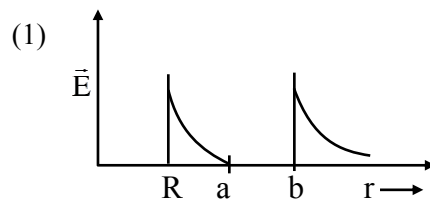
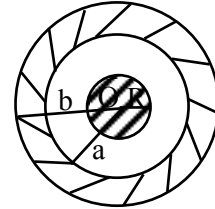

Official Ans. by NTA (1)

Official Ans. by ALLEN (1 or 2)

Sol. Considering outer spherical shell is non-conducting

Electric field inside a metal sphere is zero.

$$r < R \Rightarrow E = 0$$

$$r > R \Rightarrow E = \frac{kQ}{r^2}$$

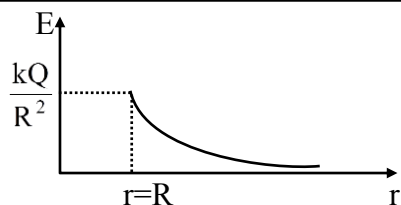

Option (2)

Considering outer spherical shell is conducting

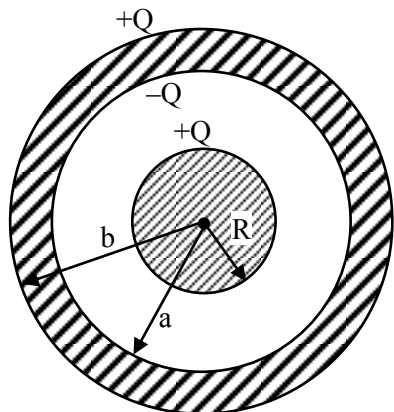

$r < R, E = 0$

$R \leq r < a, E = \frac{kQ}{r^2}$

$a \leq r < b, E = 0$

$r \geq b, E = \frac{kQ}{r^2}$

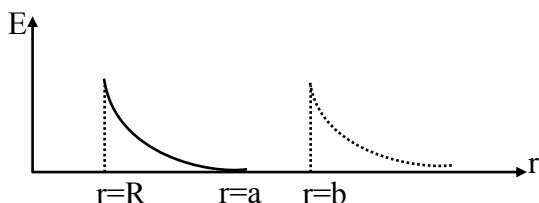

Option (1)

14. The rms speeds of the molecules of Hydrogen, Oxygen and Carbondioxide at the same temperature are V_H, V_O and V_C respectively then :

- (1) $V_H > V_O > V_C$ (2) $V_C > V_O > V_H$
 (3) $V_H = V_O > V_C$ (4) $V_H = V_O = V_C$

Official Ans. by NTA (1)

Sol. $V_{RMS} = \sqrt{\frac{3RT}{M_w}}$

At the same temperature $V_{RMS} \propto \frac{1}{\sqrt{M_w}}$

$\Rightarrow V_H > V_O > V_C$

Option (1)

15. In a Screw Gauge, fifth division of the circular scale coincides with the reference line when the ratchet is closed. There are 50 divisions on the circular scale, and the main scale moves by 0.5 mm on a complete rotation. For a particular observation the reading on the main scale is 5 mm and the 20th division of the circular scale coincides with reference line. Calculate the true reading.

- (1) 5.00 mm (2) 5.25 mm
 (3) 5.15 mm (4) 5.20 mm

Official Ans. by NTA (3)

Sol. Least count (L.C) = $\frac{0.5}{50}$

True reading = $5 + \frac{0.5}{50} \times 20 - \frac{0.5}{50} \times 5$

= $5 + \frac{0.5}{50} (15) = 5.15 \text{ mm}$

Option (3)

16. What equal length of an iron wire and a copper-nickel alloy wire, each of 2 mm diameter connected parallel to give an equivalent resistance of 3Ω ?

(Given resistivities of iron and copper-nickel alloy wire are $12 \mu\Omega \text{ cm}$ and $51 \mu\Omega \text{ cm}$ respectively)

- (1) 82 m (2) 97 m
 (3) 110 m (4) 90 m

Official Ans. by NTA (2)

Sol. $\frac{R_1 R_2}{R_1 + R_2} = 3$

$$\frac{(12 \times 10^{-6} \times 10^{-2}) \ell \times 4}{\pi (2)^2 \times 10^{-6}} \times \frac{(51 \times 10^{-6} \times 10^{-2}) \ell \times 4}{\pi (2)^2 \times 10^{-6}} = 3$$

$$\frac{63 \times 10^{-6} \times 10^{-2} \times \ell \times 4}{\pi (2)^2 \times 10^{-6}}$$

$\Rightarrow \ell = 97 \text{ m}$

Option (2)

17. The initial mass of a rocket is 1000 kg. Calculate at what rate the fuel should be burnt so that the rocket is given an acceleration of 20 ms^{-2} . The gases come out at a relative speed of 500 ms^{-1} with respect to the rocket : [Use $g = 10 \text{ m/s}^2$]

- (1) $6.0 \times 10^2 \text{ kg s}^{-1}$ (2) 500 kg s^{-1}
 (3) 10 kg s^{-1} (4) 60 kg s^{-1}

Official Ans. by NTA (4)

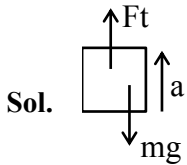

$$F_{\text{thrust}} = \left(\frac{dm}{dt} \cdot V_{\text{rel}} \right)$$

$$\left(\frac{dm}{dt} V_{\text{rel}} - mg \right) = ma$$

$$\Rightarrow \left(\frac{dm}{dt} \right) \times 500 - 10^3 \times 10 = 10^3 \times 20$$

$$\frac{dm}{dt} = (60 \text{ kg/s})$$

Option (4)

18. If E, L, M and G denote the quantities as energy, angular momentum, mass and constant of gravitation respectively, then the dimensions of P in the formula $P = EL^2M^{-5}G^{-2}$ are :-

- (1) $[M^0 L^1 T^0]$ (2) $[M^{-1} L^{-1} T^2]$
 (3) $[M^1 L^1 T^{-2}]$ (4) $[M^0 L^0 T^0]$

Official Ans. by NTA (4)

Sol. $E = ML^2T^{-2}$

$$L = ML^2T^{-1}$$

$$m = M$$

$$G = M^{-1}L^3T^{-2}$$

$$P = \frac{EL^2}{M^5G^2}$$

$$[P] = \frac{(ML^2T^{-2})(M^2L^4T^{-2})}{M^5(M^{-2}L^6T^{-4})} = M^0L^0T^0$$

Option (4)

19. The material filled between the plates of a parallel plate capacitor has resistivity $200 \Omega\text{m}$. The value of capacitance of the capacitor is 2 pF . If a potential difference of 40 V is applied across the plates of the capacitor, then the value of leakage current flowing out of the capacitor is : (given the value of relative permittivity of material is 50)

- (1) $9.0 \mu\text{A}$ (2) 9.0 mA
 (3) 0.9 mA (4) $0.9 \mu\text{A}$

Official Ans. by NTA (3)

Sol. $\rho = 200 \Omega\text{m}$

$$C = 2 \times 10^{-12} \text{ F}$$

$$V = 40 \text{ V}$$

$$K = 56$$

$$i = \frac{q}{\rho k \epsilon_0} = \frac{q_0}{\rho k \epsilon_0} e^{-\frac{t}{\rho k \epsilon_0}}$$

$$i_{\text{max}} = \frac{2 \times 10^{-12} \times 40}{200 \times 50 \times 8.85 \times 10^{-12}}$$

$$= \frac{80}{10^4 \times 8.85} = 903 \mu\text{A} = 0.9 \text{ mA}$$

Option (3)

20. **Statement-I** : By doping silicon semiconductor with pentavalent material, the electrons density increases.

Statement-II : The n-type semiconductor has net negative charge.

In the light of the above statements, choose the most appropriate answer from the options given below :

- (1) Statement-I is true but Statement-II is false.
 (2) Statement-I is false but Statement-II is true.
 (3) Both Statement-I and Statement-II are true.
 (4) Both Statement-I and Statement-II are false.

Official Ans. by NTA (1)

Sol. Pentavalent activities have excess free e^-

So e^- density increases but overall semiconductor is neutral.

Option (1)

SECTION-B

1. A uniform chain of length 3 meter and mass 3 kg overhangs a smooth table with 2 meter laying on the table. If k is the kinetic energy of the chain in joule as it completely slips off the table, then the value of k is (Take $g = 10 \text{ m/s}^2$)

Official Ans. by NTA (40)

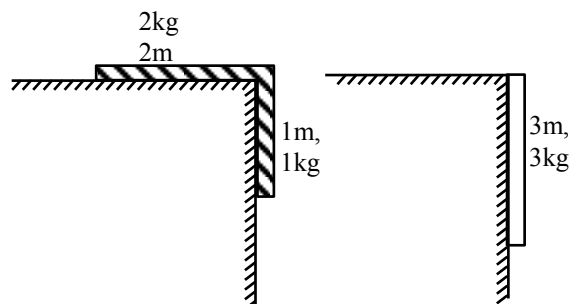

Sol.

From energy conservation

$$K_i + U_i = k_f + U_f$$

$$0 + \left(-1 \times 10 \times \frac{1}{2}\right) = k_f + \left(-3 \times 10 \times \frac{3}{2}\right)$$

$$-5 = k_f - 45$$

$$k_f = 40 \text{ J}$$

Ans. 40.00

2. The electric field in a plane electromagnetic wave is given by

$$\vec{E} = 200 \cos \left[\left(\frac{0.5 \times 10^3}{\text{m}} \right) x - \left(1.5 \times 10^{11} \frac{\text{rad}}{\text{s}} \times t \right) \right] \frac{\text{V}}{\text{m}} \hat{j}$$

If this wave falls normally on a perfectly reflecting surface having an area of 100 cm^2 . If the radiation pressure exerted by the E.M. wave on the surface during a 10 minute exposure is $\frac{x}{10^9} \frac{\text{N}}{\text{m}^2}$. Find the value of x.

Official Ans. by NTA (354)

Sol. $E_0 = 200$

$$I = \frac{1}{2} \epsilon_0 E_0^2 \cdot C$$

Radiation pressure

$$P = \frac{2I}{C}$$

$$= \left(\frac{2}{C}\right) \left(\frac{1}{2} \epsilon_0 E_0^2 C\right)$$

$$= \epsilon_0 E_0^2$$

$$= 8.85 \times 10^{-12} \times 200^2$$

$$= 8.85 \times 10^{-8} \times 4$$

$$= \frac{354}{10^9}$$

Ans. 354.0

3. A source and a detector move away from each other in absence of wind with a speed of 20 m/s with respect to the ground. If the detector detects a frequency of 1800 Hz of the sound coming from the source, then the original frequency of source considering speed of sound in air 340 m/s will be Hz.

Official Ans. by NTA (2025)

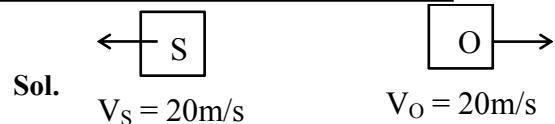

$$f' = f \left(\frac{C - V_0}{C + V_s} \right)$$

$$1800 = f \left(\frac{340 - 20}{340 + 20} \right)$$

$$f = 2025 \text{ Hz}$$

Ans. 2025

4. Two spherical balls having equal masses with radius of 5 cm each are thrown upwards along the same vertical direction at an interval of 3s with the same initial velocity of 35 m/s, then these balls collide at a height of m. (Take $g = 10 \text{ m/s}^2$)

Official Ans. by NTA (50)

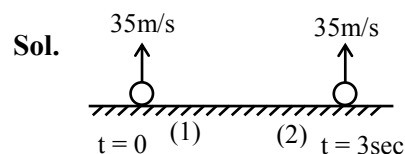

When both balls will collide

$$y_1 = y_2$$

$$35t - \frac{1}{2} \times 10 \times t^2 = 35(t-3) - \frac{1}{2} \times 10 \times (t-3)^2$$

$$35t - \frac{1}{2} \times 10 \times t^2 = 35t - 105 - \frac{1}{2} \times 10 \times t^2$$

$$-\frac{1}{2} \times 10 \times 3^2 + \frac{1}{2} \times 10 \times 6t$$

$$0 = 150 - 30t$$

$$t = 5 \text{ sec}$$

\therefore Height at which both balls will collide

$$h = 35t - \frac{1}{2} \times 10 \times t^2$$

$$= 35 \times 5 - \frac{1}{2} \times 10 \times 5^2$$

$$h = 50 \text{ m}$$

Ans. 50.00

5. A soap bubble of radius 3 cm is formed inside the another soap bubble of radius 6 cm. The radius of an equivalent soap bubble which has the same excess pressure as inside the smaller bubble with respect to the atmospheric pressure is cm.

Official Ans. by NTA (2)

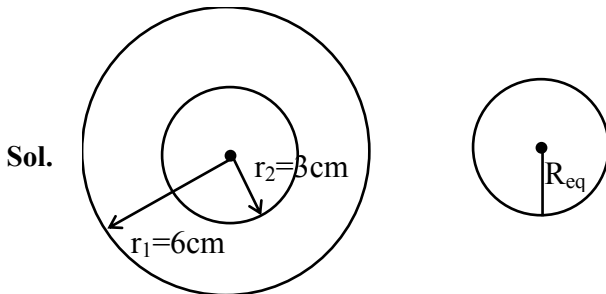

Excess pressure inside the smaller soap bubble

$$\Delta P = \frac{4S}{r_1} + \frac{4S}{r_2} \quad \dots (i)$$

The excess pressure inside the equivalent soap bubble

$$\Delta P = \frac{4S}{R_{eq}} \quad \dots (ii)$$

From (i) & (ii)

$$\frac{4S}{R_{eq}} = \frac{4S}{r_1} + \frac{4S}{r_2}$$

$$\frac{1}{R_{eq}} = \frac{1}{r_1} + \frac{1}{r_2}$$

$$= \frac{1}{6} + \frac{1}{3}$$

$$R_{eq} = 2 \text{ cm}$$

Ans. 2.00

6. An amplitude modulated wave is represented by $C_m(t) = 10(1 + 0.2 \cos 12560t) \sin(111 \times 10^4 t)$ volts.

The modulating frequency in kHz will be

Official Ans. by NTA (2)

Sol. $W_m = 12560 = 2\pi f_m$

$$f_m = \frac{12560}{2\pi}$$

$$= 2000 \text{ Hz}$$

Ans. 2.00

7. Two short magnetic dipoles m_1 and m_2 each having magnetic moment of 1 Am^2 are placed at point O and P respectively. The distance between OP is 1 meter. The torque experienced by the magnetic dipole m_2 due to the presence of m_1 is $\times 10^{-7} \text{ Nm}$.

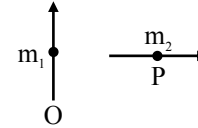

Official Ans. by NTA (1)

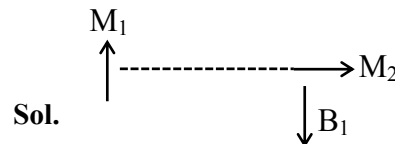

$$\vec{\tau} = \vec{M}_2 \times \vec{B}_1$$

$$\tau = M_2 B_1 \sin 90^\circ$$

$$= 1 \times \frac{\mu_0}{4\pi} \frac{M_1}{(1)^3} 1$$

$$= 10^{-7} \text{ N.m}$$

Ans. 1.00

8. Two travelling waves produces a standing wave represented by equation,

$$y = 1.0 \text{ mm} \cos(1.57 \text{ cm}^{-1} x) \sin(78.5 \text{ s}^{-1} t).$$

The node closest to the origin in the region $x > 0$ will be at $x = \dots$ cm.

Official Ans. by NTA (1)

Sol. For node

$$\cos(1.57 \text{ cm}^{-1} x) = 0$$

$$(1.57 \text{ cm}^{-1} x) = \frac{\pi}{2}$$

$$x = \frac{\pi}{2(1.57)} \text{ cm} = 1 \text{ cm}$$

Ans. 1.00

9. White light is passed through a double slit and interference is observed on a screen 1.5 m away. The separation between the slits is 0.3 mm. The first violet and red fringes are formed 2.0 mm and 3.5 mm away from the central white fringes. The difference in wavelengths of red and violet light is nm.

Official Ans. by NTA (300)

Sol. Position of bright fringe $y = n \frac{D\lambda}{d}$

$$y_1 \text{ of red} = \frac{D\lambda_r}{d} = 3.5\text{mm}$$

$$\lambda_r = 3.5 \times 10^{-3} \frac{d}{D}$$

Similarly $\lambda_v = 2 \times 10^{-3} \frac{d}{D}$

$$\lambda_r - \lambda_v = (1.5 \times 10^{-3}) \left(\frac{0.3 \times 10^{-3}}{1.5} \right)$$

$$= 3 \times 10^{-7} = 300 \text{ nm}$$

Ans. 300.0

- 10.** Consider a badminton racket with length scales as shown in the figure.

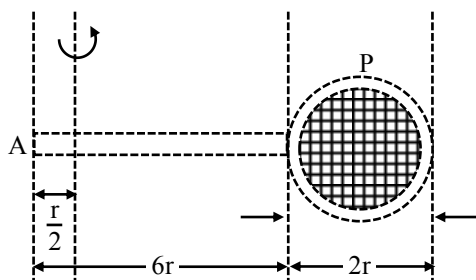

If the mass of the linear and circular portions of the badminton racket are same (M) and the mass of the threads are negligible, the moment of inertia of the racket about an axis perpendicular to the handle and in the plane of the ring at, $\frac{r}{2}$ distance from the end A of the handle will be Mr^2 .

Official Ans. by NTA (52)

Sol.

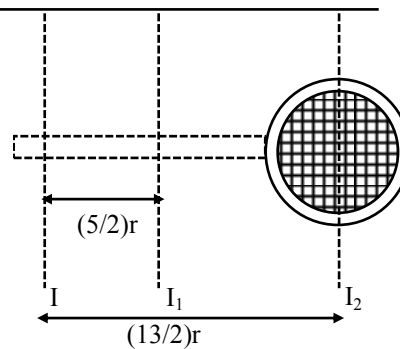

$$I = \left[I_1 + M \left(\frac{5}{2}r \right)^2 \right] + \left[I_2 + M \left(\frac{13r}{2} \right)^2 \right]$$

$$= \left[\frac{M(36r^2)}{12} + \frac{M(25r^2)}{4} \right] + \left[\frac{Mr^2}{2} + \frac{169Mr^2}{4} \right]$$

$$= 52 Mr^2$$

Ans. 52.00