

FINAL JEE-MAIN EXAMINATION – APRIL, 2023

(Held On Saturday 08th April, 2023)

TIME : 3 : 00 PM to 6 : 00 PM

PHYSICS

TEST PAPER WITH SOLUTION

SECTION-A

31. Electric potential at a point 'P' due to a point charge of 5×10^{-9} C is 50 V. The distance of 'P' from the point charge is:

(Assume, $\frac{1}{4\pi\epsilon_0} = 9 \times 10^9 \text{ Nm}^2\text{C}^{-2}$)

- (1) 3 cm (2) 9 cm
(3) 90 cm (4) 0.9 cm

Official Ans. by NTA (3)

Ans. (3)

Sol. $V_p = \frac{KQ}{r}$

$$50 = \frac{9 \times 10^9 \times 5 \times 10^{-9}}{r}$$

$$r = \frac{45}{50} = \frac{9}{10} = 0.9\text{m} = 90\text{cm}$$

32. For particle P revolving round the centre O with radius of circular path r and angular velocity ω , as shown in below figure, the projection of OP on the x-axis at time t is

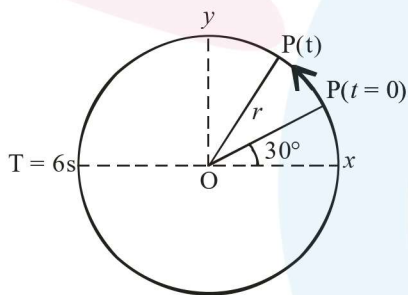

- (1) $x(t) = r \cos\left(\omega t + \frac{\pi}{6}\right)$
(2) $x(t) = r \cos(\omega t)$
(3) $x(t) = r \sin\left(\omega t + \frac{\pi}{6}\right)$
(4) $x(t) = r \cos\left(\omega t - \frac{\pi}{6}\right)$

Official Ans. by NTA (1)

Ans. (1)

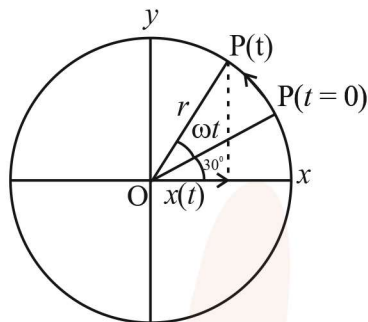

Sol.

$$x(t) = r \cos(\omega t + 30^\circ)$$

$$x(t) = r \cos(\omega t + \pi/6)$$

33. Match List I with List II

LIST-I		LIST-II	
A.	Torque	I.	$\text{ML}^{-2}\text{T}^{-2}$
B.	Stress	II.	ML^2T^{-2}
C.	Pressure gradient	III.	$\text{ML}^{-1}\text{T}^{-1}$
D.	Coefficient of viscosity	IV.	$\text{ML}^{-1}\text{T}^{-2}$

Choose the correct answer from the options given below:

- (1) A-III, B-IV, C-I, D-II
(2) A-IV, B-II, C-III, D-I
(3) A-II, B-IV, C-I, D-III
(4) A-II, B-I, C-IV, D-III

Official Ans. by NTA (3)

Ans. (3)

Sol. A. Torque $\Rightarrow \vec{\tau} = \vec{r} \times \vec{F}$

$$[\tau] = [L][\text{MLT}^{-2}]$$

$$\Rightarrow \text{ML}^2\text{T}^{-2}$$

B. Stress = $\frac{F}{A} \Rightarrow \frac{\text{MLT}^{-2}}{\text{L}^2}$

$$[\text{stress}] = \text{ML}^{-1}\text{T}^{-2}$$

C. Pressure gradient = $\frac{\Delta P}{\Delta X}$

$$\Rightarrow \frac{[F/A]}{[L]} \Rightarrow \frac{\text{MLT}^{-2}}{\text{L}^3}$$

$$\Rightarrow \text{ML}^{-2}\text{T}^{-2}$$

D. Coefficient of viscosity $\Rightarrow F = 6\pi\eta rv$

$$\text{MLT}^{-2} = [\eta] \text{L}^2\text{T}^{-1}$$

$$[\eta] = \text{ML}^{-1}\text{T}^{-1}$$

34. For a given transistor amplifier circuit in CE configuration $V_{CC} = 1\text{ V}$, $R_c = 1\text{ k}\Omega$, $R_b = 100\text{ k}\Omega$ and $\beta = 100$. Value of base current I_b is

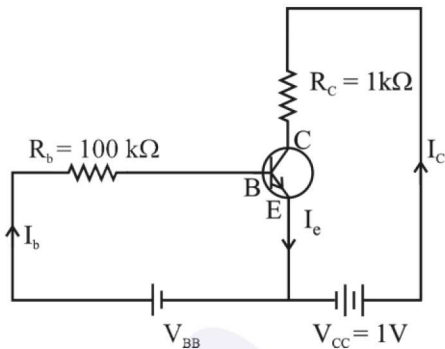

- (1) $I_b = 1.0\ \mu\text{A}$ (2) $I_b = 0.10\ \mu\text{A}$
 (3) $I_b = 100\ \mu\text{A}$ (4) $I_b = 10\ \mu\text{A}$

Official Ans. by NTA (4)

Ans. (4)

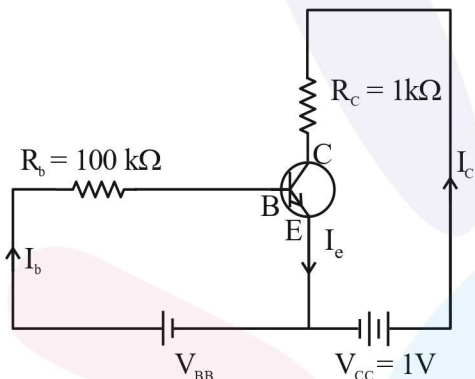

Sol.

Considering the transistor in saturation mode

$$V_{CE} = 0$$

Using KVL

$$-I_c R_c + V_{CC} = 0$$

$$I_c = \frac{V_{CC}}{R_c} = \frac{1}{1 \times 10^3}$$

$$I_c = 10^{-3}\text{ A}$$

$$\beta = \frac{I_c}{I_b}$$

$$I_b = \frac{10^{-3}}{100} \Rightarrow 10^{-5}\text{ A} \Rightarrow I_b = 10\ \mu\text{A}$$

35. The trajectory of projectile, projected from the ground is given by $y = x - \frac{x^2}{20}$. Where x and y are measured in meter. The maximum height attained by the projectile will be.

- (1) 5 m (2) $10\sqrt{2}\text{ m}$
 (3) 200 m (4) 10 m

Official Ans. by NTA (1)

Ans. (1)

Sol. $y = x - \frac{x^2}{20}$

For maximum height,

$$\frac{dy}{dx} = 0 \Rightarrow 1 - \frac{2x}{20} = 0$$

$$x = 10$$

$$\text{So, } y_{\text{max}} = 10 - \frac{100}{20} = 5\text{ m}$$

36. A radio-active material is reduced to $1/8$ of its original amount in 3 days. If $8 \times 10^{-3}\text{ kg}$ of the material is left after 5 days. The initial amount of the material is

- (1) 64 g (2) 40 g
 (3) 32 g (4) 256 g

Official Ans. by NTA (4)

Ans. (4)

Sol. $N = N_0 \left(\frac{1}{2}\right)^n$

$$\frac{N_0}{8} = N_0 \left(\frac{1}{2}\right)^n$$

$$n = 3$$

$$3 \text{ half lives} = 3 \text{ days}$$

$$1 \text{ half life} = 1 \text{ day}$$

$$5 \text{ days} = 5 \text{ half life}$$

$$N = N_0 \left(\frac{1}{2}\right)^n$$

$$8 \times 10^{-3} = N_0 \left(\frac{1}{2}\right)^5$$

$$N_0 = 256 \times 10^{-3}\text{ kg}$$

$$N_0 = 256\text{ g}$$

37. The equivalent resistance between A and B as shown in figure is:

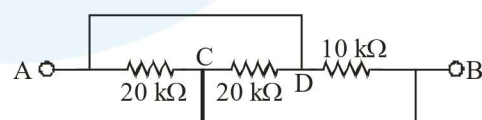

- (1) 5 kΩ (2) 30 kΩ
 (3) 10 kΩ (4) 20 kΩ

Official Ans. by NTA (1)

Ans. (1)

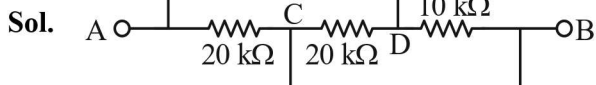

$$V_A = V_D$$

$$V_C = V_B$$

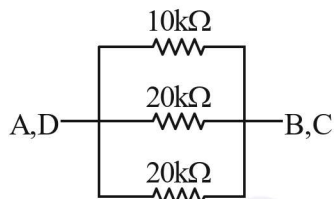

All resistors are in parallel. So,

$$\frac{1}{R_{eq}} = \frac{1}{10} + \frac{1}{20} + \frac{1}{20}$$

$$R_{eq} = 5 \text{ k}\Omega.$$

- 38.** A hydraulic automobile lift is designed to lift vehicles of mass 5000 kg. The area of cross section of the cylinder carrying the load is 250 cm². The maximum pressure the smaller piston would have to bear is [Assume $g = 10 \text{ m/s}^2$]:

- (1) $200 \times 10^{+6} \text{ Pa}$ (2) $20 \times 10^{+6} \text{ Pa}$
 (3) $2 \times 10^{+6} \text{ Pa}$ (4) $2 \times 10^{+5} \text{ Pa}$

Official Ans. by NTA (3)

Ans. (3)

Sol. Force = $mg = 5000 \text{ g}$

Area of cross section = $250 \text{ cm}^2 = 250 \times 10^{-4} \text{ m}^2$

$$\text{max imum pressure} = \frac{\text{Force}}{\text{area of cross section}}$$

$$= \frac{5000\text{g}}{250 \times 10^{-4}} = \frac{20 \times \text{g}}{10^{-4}} = 2 \times 10^6 \text{ Pa}$$

- 39.** The orbital angular momentum of a satellite is L , when it is revolving in a circular orbit at height h from earth surface. If the distance of satellite from the earth centre is increased by eight times to its initial value, then the new angular momentum will be-

- (1) $8 L$ (2) $4 L$
 (3) $9 L$ (4) $3 L$

Official Ans. by NTA (4)

Ans. (4)

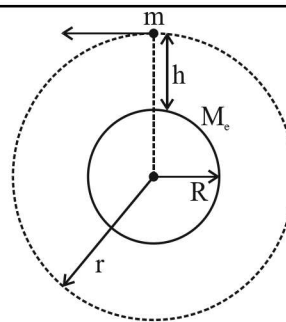

Sol.

$$L = mvr$$

$$v = \sqrt{\frac{GM_e}{r}}$$

$$L = m\sqrt{\frac{GM_e}{r}} \cdot r$$

$$L \propto r^{\frac{1}{2}}$$

Now distance from centre is increased by 8 times.

So new distance from centre = $r + 8r = 9r$

Now angular momentum $L' \propto (9r)^{1/2}$

$$\frac{L}{L'} = \frac{r^{1/2}}{(9r)^{1/2}} = \frac{1}{3}$$

$$L' = 3 L$$

- 40.** The temperature at which the kinetic energy of oxygen molecules becomes double than its value at 27°C is

- (1) 1227° C (2) 927° C
 (3) 327° C (4) 627° C

Official Ans. by NTA (3)

Ans. (3)

Sol. Kinetic energy = $\frac{f}{2} kT$, T is absolute temperature.

If K_1 is kinetic energy at 27°C.

K_2 is kinetic energy at new temperature T .

$$\frac{K_1}{K_2} = \frac{T_1}{T_2} \Rightarrow \frac{1}{2} = \frac{300}{T}$$

$$T = 600 \text{ K}$$

$$T = 327^\circ\text{C}$$

- 41.** The acceleration due to gravity at height h above the earth if $h \ll R$ (radius of earth) is given by

(1) $g' = g \left(1 - \frac{2h}{R} \right)$ (2) $g' = g \left(1 - \frac{2h^2}{R^2} \right)$

(3) $g' = g \left(1 - \frac{h}{2R} \right)$ (4) $g' = g \left(1 - \frac{h^2}{2R^2} \right)$

Official Ans. by NTA (1)

Ans. (1)

Sol. For point outside the surface of earth

$$g = \frac{GM}{r^2}$$

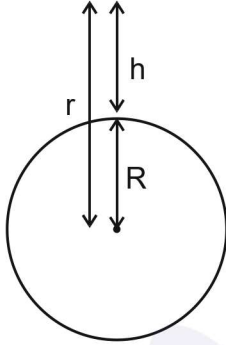

r = distance from center of earth

$$\Rightarrow g(h) = \frac{GM}{(R+h)^2} \Rightarrow g(h) = \frac{GM}{R^2 \left(1 + \frac{h}{R}\right)^2}$$

$$\Rightarrow g(h) = \frac{GM}{R^2} \left(1 + \frac{h}{R}\right)^{-2}$$

If $h \ll R$, $\left(1 + \frac{h}{R}\right)^{-2} \approx 1 - \frac{2h}{R}$

$$\Rightarrow g(h) = \frac{GM}{R^2} \left(1 - \frac{2h}{R}\right)$$

$$\Rightarrow g(h) = g_{\text{surface}} \left(1 - \frac{2h}{R}\right), \frac{GM}{R^2} = g_{\text{surface}}$$

42. Work done by a Carnot engine operating between temperatures 127°C and 27°C is 2 kJ. The amount of heat transferred to the engine by the reservoir is:

- (1) 4kJ (2) 2 kJ
 (3) 8kJ (4) 2.67 kJ

Official Ans. by NTA (3)

Ans. (3)

Sol.

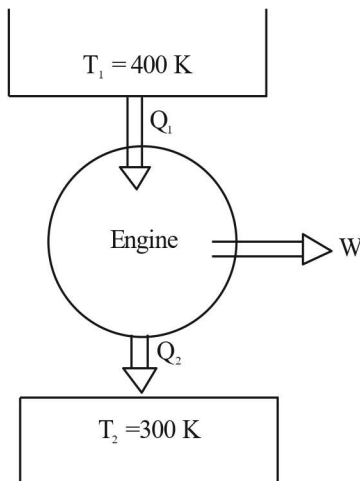

Efficiency of carnot engine

$$\eta = 1 - \frac{T_2}{T_1} = \frac{W}{Q_1}$$

$$\Rightarrow \frac{W}{Q_1} = 1 - \frac{300}{400} = \frac{1}{4}$$

$$\Rightarrow \frac{2\text{kJ}}{Q_1} = \frac{1}{4}$$

$$\Rightarrow Q_1 = 8 \text{ kJ}$$

43. Given below are two statements:

Statement I: Area under velocity- time graph gives the distance travelled by the body in a given time.

Statement II: Area under acceleration- time graph is equal to the change in velocity- in the given time.

In the light of given statements, choose the correct answer from the options given below.

- (1) Both Statement I and Statement II are true.
 (2) Statement I is correct but Statement II is false.
 (3) Statement I is incorrect but Statement II is true.
 (4) Both Statement I and Statement II are False.

Official Ans. by NTA (1)

Ans. (3)

Sol. Area under velocity time graph gives displacement of body in given time.

Area under acceleration time graph gives change in velocity in the given time.

So Statement I false

Statement II True

44. The waves emitted when a metal target is bombarded with high energy electrons are

- (1) Microwaves (2) X-rays
 (3) Infrared rays (4) Radio Waves

Official Ans. by NTA (2)

Ans. (2)

Sol. X rays are emitted when target metal is bombarded with high energy electron.

45. The width of fringe is 2 mm on the screen in a double slits experiment for the light of wavelength of 400 nm. The width of the fringe for the light of wavelength 600 nm will be:

- (1) 4 mm (2) 1.33 mm
 (3) 3 mm (4) 2 mm

Official Ans. by NTA (3)

Ans. (3)

Sol. Fringe width $(\beta) = \frac{D\lambda}{d}$

$$\Rightarrow \frac{\beta_2}{\beta_1} = \frac{\lambda_2}{\lambda_1}$$

$$\Rightarrow \frac{\beta_2}{2\text{mm}} = \frac{600\text{nm}}{400\text{nm}} = \frac{3}{2}$$

$$\Rightarrow \boxed{\beta_2 = 3\text{mm}}$$

46. Given below are two statements; one is labelled as Assertion A and the other is labelled as Reason R
Assertion A: Electromagnets are made of soft iron.

Reason R: Soft iron has high permeability and low retentivity.

In the light of above, statements, choose the most appropriate answer from the options given below.

- (1) A is not correct but R is correct
- (2) Both A and R are correct and R is the correct explanation of A
- (3) Both A and R are correct but R is NOT the correct explanation of A
- (4) A is correct but R is not correct

Official Ans. by NTA (2)

Ans. (2)

Sol. Electromagnets are made of soft iron because it has high permeability and low retentivity.

So, Both A and R are correct and R is the correct explanation of A

47. In photo electric effect

- A. The photocurrent is proportional to the intensity of the incident radiation.
- B. Maximum Kinetic energy with which photoelectrons are emitted depends on the intensity of incident light.
- C. Max. K.E with which photoelectrons are emitted depends on the frequency of incident light.
- D. The emission of photoelectrons require a minimum threshold intensity of incident radiation.
- E. Max. K.E of the photoelectrons is independent of the frequency of the incident light.

Choose the correct answer from the options given below:

- (1) A and C only (2) A and E only
- (3) B and C only (4) A and B only

Official Ans. by NTA (1)

Ans. (1)

Sol. Intensity of light \propto number of photons \propto no of photo electrons \propto photo current

So, A is correct

$$KE_{\text{max}} = hv - \phi$$

KE_{max} depends on frequency

So, C is correct

So, A and C are correct

48. An emf of 0.08 V is induced in a metal rod of length 10 cm held normal to a uniform magnetic field of 0.4 T, when moves with a velocity of:

- (1) 2 ms⁻¹ (2) 3.2 ms⁻¹
- (3) 0.5 ms⁻¹ (4) 20 ms⁻¹

Sol. Official Ans. by NTA (1)

Ans. (1)

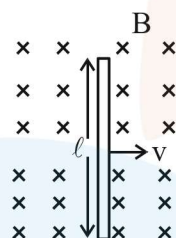

$$\text{Induced emf} = Blv$$

$$\Rightarrow 0.08 = 0.4 \left(\frac{10}{100} \right) v$$

$$\Rightarrow v = \left(\frac{0.08 \times 10}{0.4} \right) \Rightarrow v = 2\text{m/s}$$

49. A bullet of mass 0.1 kg moving horizontally with speed 400 ms⁻¹ hits a wooden block of mass 3.9 kg kept on a horizontal rough surface. The bullet gets embedded into the block and moves 20 m before coming to rest. The coefficient of friction between the block and the surface is _____.

(Given $g = 10 \text{ ms}^{-2}$)

- (1) 0.50 (2) 0.90
- (3) 0.65 (4) 0.25

Official Ans. by NTA (4)

Ans. (4)

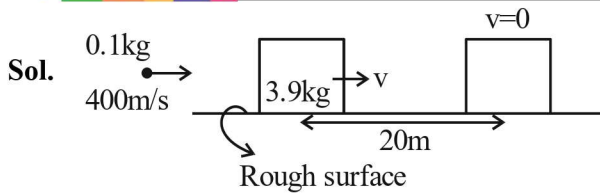

$$P_i = P_f \text{ (Collision)}$$

$$\Rightarrow (0.1)(400) = (0.1+3.9)v$$

$$\Rightarrow v = \frac{0.1 \times 400}{4} = 10 \text{ m/s}$$

$$a = \frac{\mu mg}{m} = \mu g$$

Apply equation of motion,

$$v^2 = u^2 + 2as$$

$$\Rightarrow 0 = (10)^2 - 2\mu g \times 20$$

$$\Rightarrow 40\mu g = 100$$

$$\Rightarrow \mu = \frac{100}{2 \times 10 \times 20} = \frac{1}{4}$$

50. The power radiated from a linear antenna of length l is proportional to

(Given, λ = Wavelength of wave):

- (1) $\frac{l}{\lambda}$ (2) $\frac{l}{\lambda^2}$ (3) $\frac{l^2}{\lambda}$ (4) $\left(\frac{l}{\lambda}\right)^2$

Official Ans. by NTA (4)

Ans. (4)

Sol. Power radiated from a linear antenna of length $l \propto \left(\frac{l}{\lambda}\right)^2$

SECTION-B

51. A series combination of resistor of resistance 100 Ω , inductor of inductance 1 H and capacitor of capacitance 6.25 μF is connected to an ac source. The quality factor of the circuit will be _____.

Official Ans. by NTA 4

Ans. 4

Sol. Quality factor = $\frac{X_L}{R} = \frac{\omega L}{R}$

$$\omega = \frac{1}{\sqrt{LC}} = \frac{1}{\sqrt{1 \times 6.25 \times 10^{-6}}} = \frac{10^3}{2.5} = 400 / \text{sec}$$

$$\text{Q-factor} = \frac{400 \times 1}{100} = 4$$

52. A guitar string of length 90 cm vibrates with a fundamental frequency of 120 Hz. The length of the string producing a fundamental frequency of 180 Hz will be _____ cm.

Official Ans. by NTA 60

Ans. 60

Sol. $f = \frac{nv}{2l}$, for fundamental mode $n = 1$

$$f = \frac{v}{2l}$$

$$f \propto \frac{1}{l}$$

$$\frac{f_1}{f_2} = \frac{l_2}{l_1}$$

$$\frac{120}{180} = \frac{l_2}{90}$$

$$l_2 = 60 \text{ cm}$$

53. The ratio of wavelength of spectral lines H_α and H_β in the Balmer series is $\frac{x}{20}$. The value of x is _____.

Official Ans. by NTA 27

Ans. 27

Sol. $\frac{1}{\lambda} = R \left[\frac{1}{n_1^2} - \frac{1}{n_2^2} \right]$ for H-atom

For balmer series, $n_1 = 2$

$$\frac{1}{\lambda} = R \left[\frac{1}{4} - \frac{1}{n_2^2} \right]$$

For H_α , $n_2 = 3$

& H_β , $n_2 = 4$

$$\frac{1}{\lambda_{H_\alpha}} = R \left[\frac{1}{4} - \frac{1}{9} \right] = \frac{5R}{36}$$

$$\frac{1}{\lambda_{H_\beta}} = R \left[\frac{1}{4} - \frac{1}{16} \right] = \frac{3R}{16}$$

$$\frac{1}{\lambda_{H_\alpha}} = \frac{5R}{36}$$

$$\frac{1}{\lambda_{H_\beta}} = \frac{3R}{16}$$

$$\frac{\lambda_{H_\alpha}}{\lambda_{H_\beta}} = \frac{27}{20} = \frac{x}{20}$$

$$x = 27$$

54. The number density of free electrons in copper is nearly $8 \times 10^{28} \text{ m}^{-3}$. A copper wire has its area of cross section = $2 \times 10^{-6} \text{ m}^2$ and is carrying a current of 3.2 A. The drift speed of the electrons is _____ $\times 10^{-6} \text{ ms}^{-1}$.

Official Ans. by NTA 125

Ans. 125

Sol. $n = 8 \times 10^{28} \text{ m}^{-3}$
 Area = $2 \times 10^{-6} \text{ m}^2$
 $I = 3.2 \text{ A}$
 $I = neAv_d$
 $V_d = \frac{I}{neA} = 125 \times 10^{-6} \text{ m/s}$

55. A steel rod of length 1 m and cross sectional area 10^{-4} m^2 is heated from 0°C to 200°C without being allowed to extend or bend. The compressive tension produced in the rod is _____ $\times 10^4 \text{ N}$. (Given Young's modulus of steel = $2 \times 10^{11} \text{ Nm}^{-2}$, coefficient of linear expansion = 10^{-5} K^{-1}).

Official Ans. by NTA 4

Ans. 4

Sol. Stress = $Y \times$ strain
 Stress = $Y \times \frac{\Delta \ell}{\ell}$
 $= Y \times \frac{\ell \alpha \Delta T}{\ell} = Y \alpha \Delta T$

Compressive Tension = Stress \times Area of cross section
 $= Y \alpha \Delta T = 4 \times 10^4 \text{ N}$

56. A hollow spherical ball of uniform density rolls up a curved surface with an initial velocity 3 m/s (as shown in figure). Maximum height with respect to the initial position covered by it will be _____ cm.

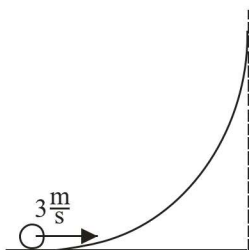

Official Ans. by NTA 75

Ans. 75

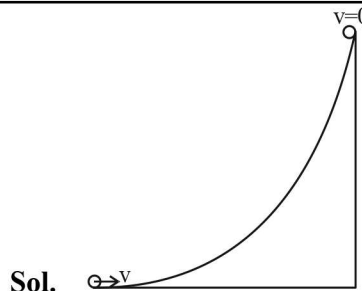

Sol.

At highest point $KE_f = 0$

Initial KE = Translational KE + Rotational KE

$$= \frac{1}{2}mv^2 + \frac{1}{2}I\omega^2$$

In case of rolling $v = R\omega$

$$= \frac{1}{2}mv^2 + \frac{1}{2} \times \frac{2}{3}mR^2 \times \frac{v^2}{R^2}$$

$$= \frac{5}{6}mv^2$$

Apply energy conservation

$$KE_i + PE_i = KE_f + PE_f$$

$$\frac{5}{6}mv^2 = mgh$$

$$h = \frac{5}{6 \times 10} \times 9m = \frac{15}{20}m = 75\text{cm}$$

57. A body of mass 5 kg is moving with a momentum of 10 kg ms^{-1} . Now a force of 2 N acts on the body in the direction of its motion for 5 s. The increase in the Kinetic energy of the body is _____ J.

Official Ans. by NTA (30)

Ans. (30)

Sol. Given
 $M = 5 \text{ kg}$
 $P_i = 10 \text{ kg m/s}$ (initial momentum)
 Impulse = $F\Delta t = \Delta P = P_f - P_i$
 $2 \times 5 = P_f - 10$
 $P_f = 20 \text{ kg m/s}$ (final momentum)
 Increase in KE = $KE_f - KE_i$

$$= \frac{P_f^2}{2m} - \frac{P_i^2}{2m}$$

$$= \frac{400}{2 \times 5} - \frac{100}{2 \times 5} = 40 - 10 = 30\text{J}$$

58. A 600 pF capacitor is charged by 200V supply. It is then disconnected from the supply and is connected to another uncharged 600 pF capacitor. Electrostatic energy lost in the process is _____ μJ .

Official Ans. by NTA (6)

Ans. (6)

Sol.

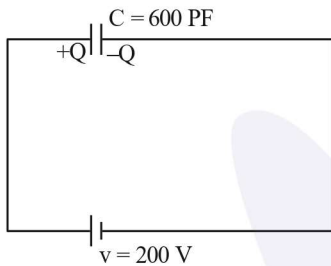

$$Q = CV = 600 \times 10^{-12} \times 200 = 12 \times 10^{-8} \text{C}$$

$$\text{Initial energy} = \frac{1}{2} CV^2$$

$$= \frac{1}{2} \times 600 \times 10^{-12} \times (200)^2 = 12 \mu\text{J}$$

When connected to another uncharged capacitor

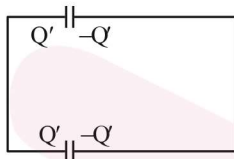

Charge will be equally distributed on identical capacitor

$$Q' = \frac{Q}{2} = 6 \times 10^{-8}$$

$$\text{Final energy} = 2 \times \frac{Q'^2}{2C} = \frac{Q'^2}{C}$$

$$\frac{(6 \times 10^{-8})^2}{600 \times 10^{-12}} = 6 \mu\text{J}$$

$$\begin{aligned} \text{Energy lost} &= \text{Initial energy} - \text{Final energy} \\ &= (12 - 6) \mu\text{J} = 6 \mu\text{J} \end{aligned}$$

59. Two transparent media having refractive indices 1.0 and 1.5 are separated by a spherical refracting surface of radius of curvature 30 cm. The centre of curvature of surface is towards denser medium and a point object is placed on the principle axis in rarer medium at a distance of 15 cm from the pole of the surface. The distance of image from the pole of the surface is _____ cm.

Official Ans. by NTA 30

Ans. 30

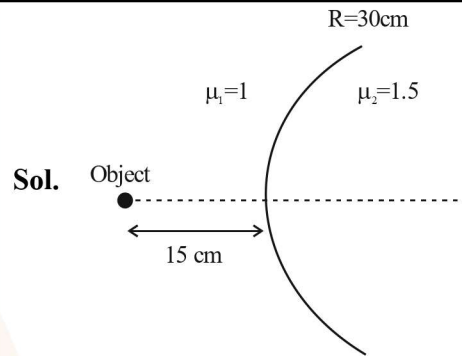

Sol.

$$\frac{\mu_2}{v} - \frac{\mu_1}{u} = \frac{\mu_2 - \mu_1}{R}$$

$$\frac{1.5}{v} - \frac{1}{-15} = \frac{1.5 - 1}{30} = \frac{1}{60}$$

$$\frac{1.5}{v} + \frac{1}{15} = \frac{1}{60}$$

$$\frac{1.5}{v} = \frac{1}{60} - \frac{1}{15} = \frac{-1}{20}$$

$$\frac{1.5}{v} = -\frac{1}{20} \Rightarrow v = -30 \text{cm}$$

60. The ratio of magnetic field at the centre of a current carrying coil of radius r to the magnetic field at distance r from the centre of coil on its axis is $\sqrt{x} : 1$. The value of x is _____

Official Ans. by NTA 8

Ans. 8

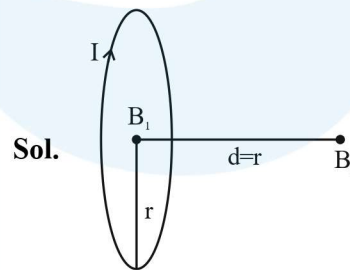

Sol.

$$\text{Magnetic field at centre } (B_1) = \frac{\mu_0 I}{2r}$$

$$\text{Magnetic field on axis} = \frac{\mu_0 I r^2}{2(r^2 + d^2)^{3/2}}$$

Value of $d = r$ (given)

$$B_2 = \frac{\mu_0 I}{4\sqrt{2}r}$$

$$\frac{B_1}{B_2} = \frac{\mu_0 I}{2r} \times \frac{4\sqrt{2}r}{\mu_0 I} = \frac{2\sqrt{2}}{1} = \frac{\sqrt{8}}{1}$$

$$x = 8$$